

RGB MATRIX PREAMPLIFIER

The TDA2532 is an integrated matrix preamplifier for use in conjunction with discrete video amplifiers to provide RGB drive to the cathodes of a colour television picture tube. The integrated circuit incorporates:

- matrix circuits;
- gain control stages, operated by d.c. setting;
- preamplifiers with feedback and integral black-level clamps;
- facilities for video blanking during data display.

The three channels have the same layout to ensure identical frequency behaviour. The integrated circuit has been designed to be driven by the integrated colour demodulator combination type TDA2522.

QUICK REFERENCE DATA

Supply voltage	V_{9-16}	typ.	12 V
Operating ambient temperature range	T_{amb}		-25 to +60 °C
Luminance input resistance	R_{1-16}	>	100 k Ω
Input current of colour difference inputs	I_2, I_4, I_6	typ.	1 μ A
Clamping pulse input current	$-I_8$	<	60 μ A
Gain of RGB preamplifiers	G	typ.	0 dB
Gain d.c. adjustment range	ΔG	>	± 40 %
Gain of error amplifier (transconductance)		typ.	20 mA/V
Output current swing	I_{10}, I_{12}, I_{14}	typ.	$\pm 3,5$ mA

PACKAGE OUTLINES

TDA2532: 16-lead DIL; plastic (SOT-38).

TDA2532Q: 16-lead QIL; plastic (SOT-58).

201

June 1978



BLOCK DIAGRAM

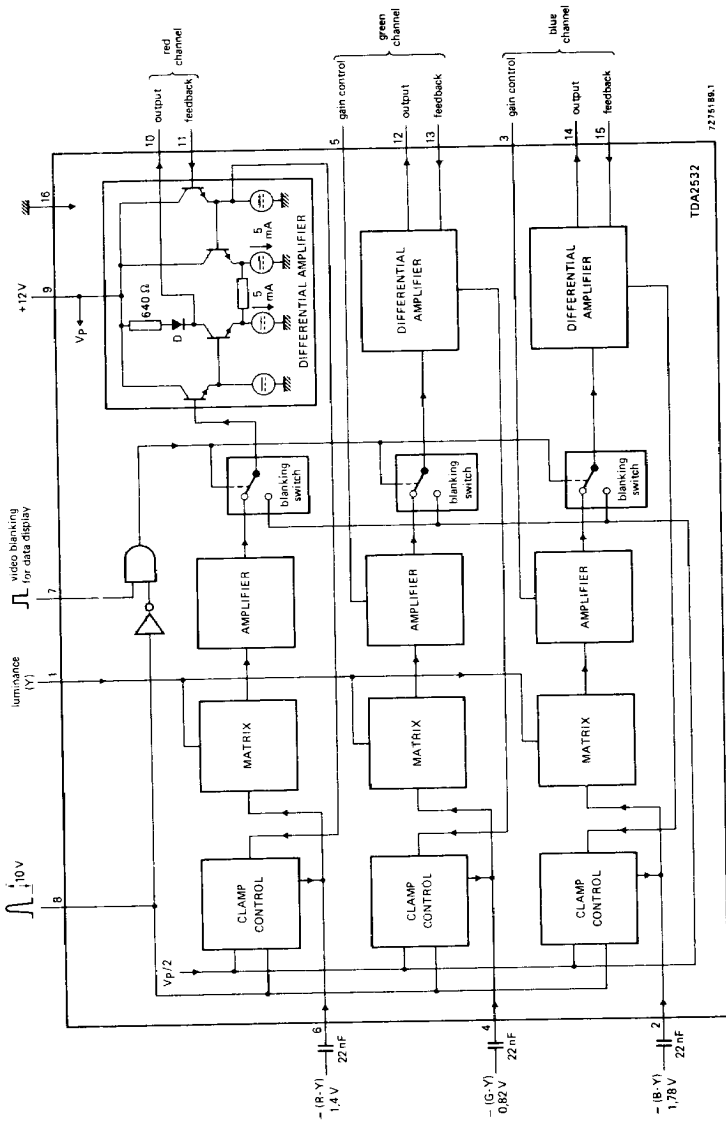

TDA2532

727818k.1

RATINGS

Limiting values in accordance with the Absolute Maximum System (IEC 134)

Supply voltage (pin 9)	V_P (V9-16)	max.	13,2 V
Pin 1	V_{1-16}		0 to V_P
Pins 3, 5	$V_{3; 5-16}$		0 to V_P
Pins 2, 4 and 6	$V_{2; 4; 6-16}$		0 to V_P
Pin 7	V_{7-16}		-0,5 V to V_P
Pin 8	V_{8-16}	max.	V_P
Pin 10	V_{10-16}		V_{11-16} to $V_P + 3$ V
Pin 12	V_{12-16}		V_{13-16} to $V_P + 3$ V
Pin 14	V_{14-16}		V_{15-16} to $V_P + 3$ V
Pins 11, 13 and 15	$V_{11; 13; 15-16}$		0,3 V_P to V_P
Pin 8	-I _g	max.	1 mA
Total power dissipation	P_{tot}	max.	1,1 W
Storage temperature	T_{stg}		-25 to + 125 °C
Operating ambient temperature	T_{amb}		-25 to + 60 °C

CHARACTERISTICS

At $V_P = 12$ V; $V_{1-16} = 1,5$ V; $T_{amb} = 25$ °C; measured in circuit on page 6.

Current consumption	I _g	typ.	60 mA
Luminance input			
Black level	V_{1-16}	typ.	1,5 V
Black-to-white input voltage (peak-to-peak value)	V_{1-16} (p-p)	typ.	1,0 V
Input resistance	R_{1-16}	>	100 kΩ
Colour difference input			
Input signals (peak-to-peak values) for 100% saturated colour bars	R-Y	V_{6-16} (p-p)	typ. 1,4 V
	G-Y	V_{4-16} (p-p)	typ. 0,82 V
	B-Y	V_{2-16} (p-p)	typ. 1,78 V
Input currents (source resistance 300 Ω max.)	I _{2, 14, 16}	typ.	1 μA
		<	3 μA

203

June 1978



CHARACTERISTICS (continued)

Clamp pulse input

Input voltage for clamping			
on level	V ₈₋₁₆		7,5 to 12 V
off level	V ₈₋₁₆		0 to 6,5 V*
Input voltage to enable video blanking input	V ₈₋₁₆	<	1 V
Input voltage to disable video blanking input	V ₈₋₁₆		2 to 12 V
Input current for clamping			
on level	I _g	<	1 μA
off level	-I _g	<	60 μA
Clamp pulse duration	t _{clamp}	>	3,5 μs

Video blanking input

Input voltage for blanking			
on level	V ₇₋₁₆	>	1,5 V
off level	V ₇₋₁₆	<	0,5 V

Feedback input

D.C. level during clamping	V _{11; 13; 15-16}		6 to 6,2 V
----------------------------	----------------------------	--	------------

Gain adjustment for colour drive

Adjustment voltage range	V _{3; 5-16}		0 to 10 V
Adjustment voltage for nominal gain	V _{3; 5-16}	typ.	5 V
Nominal gain between colour difference inputs, luminance input and colour feedback inputs (pins 11, 13 and 15)	G	typ.	0 dB**
Adjustment range of nominal gain at $\Delta V_{3; 5-16} = \pm 5$ V	ΔG	>	± 40 %

Differential amplifier

Gain of error amplifier (transconductance)		typ.	20 mA/V
Output current swing	I _{10; 12; 14}	≥	$\pm 3,5$ mA
Integrated load resistance	R _{10; 12; 14-9}	typ.	640 Ω▲
Output bias voltage (see application information)	V _{10; 12; 14-16}	typ.	8 V▲

* Switching from clamping on to off occurs at about 7 V.

** Error signal is assumed to be negligible.

▲ The fact that the load resistors have series diodes (D; see block diagram on page 2), means that the resistors can be ignored when V_{10; 12; 14} ≥ V_p. In that case, external load resistors must be chosen such that the nominal current will be 3,5 mA.

APPLICATION INFORMATION (see circuit on page 6)

Clamping level (V_{cl}) of video output stages, with set clamping level potentiometers in their mid-positions:

$$V_{cl} = 0,5 V_P \left(1 + \frac{R_1}{R_2} - \frac{R_1}{R_3} \right).$$

Gain of video output stages: $G = 1 + \frac{R_1}{R_2} + \frac{R_1}{R_3} + \frac{R_1}{R_4 + 0,25 R_5}$.

205

June 1978



APPLICATION INFORMATION

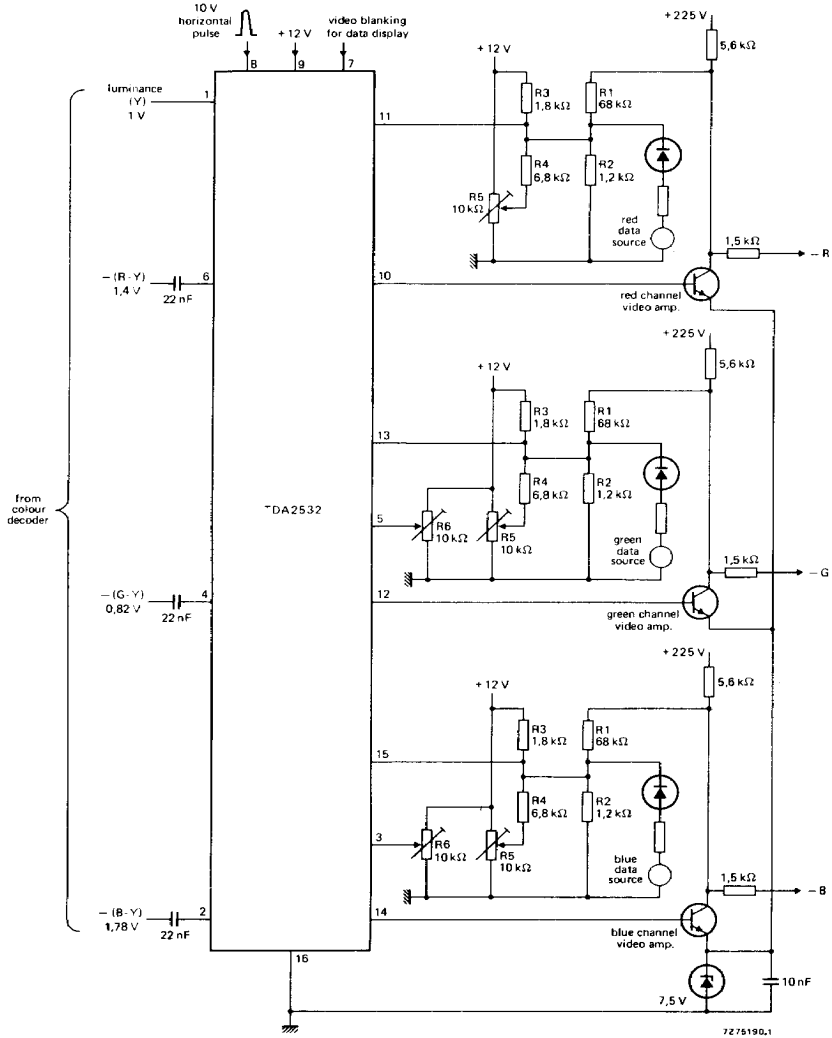

R5 = clamping level adjustment (70 V to 170 V); R6 = gain adjustment (65 to 140).