

TA7739P/F

www.DataSheet4U.com

3V DUAL PREAMPLIFIER.

The TA7739P(DIP-16) and TA7739F(MFP-16-SO) are dual preamplifier designed for a 3V operation automatic reverse type headphone stereo application.

- Built-in Forward/Reverse Control Switch
- Built-in Metal/Normal Control Switch
- No Input Coupling Capacitor
- Low Noise : $V_{NI}=0.9\mu V_{rms}$ (Typ.)
($R_g=2.2k\Omega$, $NAB(G_v=40dB$, $f=1kHz)$)
- Low Supply Current
: $I_{CCQ}=1.8mA$ (Typ.) ($V_{CC}=3V$, $V_{IN}=0V$)
- High Output Voltage
: $V_{OM}=0.9V_{rms}$ (Typ.) ($THD=0.5%$, $V_{CC}=3V$)
- Wide Operating Supply Voltage : $V_{CC}=1.6V\sim 5V$ ($T_a=25^\circ C$)

MAXIMUM RATINGS ($T_a=25^\circ C$)

CHARACTERISTIC		SYMBOL	RATING	UNIT
Supply Voltage		V_{CC}	6	V
Power Dissipation (Note)	TA7739P	P_{D1}	750	mW
	TA7739F	P_{D2}	350	
Operating Temperature		T_{opr}	-25~75	$^\circ C$
Storage Temperature		T_{stg}	-55~150	$^\circ C$

Note: Derated above $T_a=25^\circ C$ in the proportion of $6mW/^\circ C$ for TA7739P and of $2.8mW/^\circ C$ for TA7739F.

Unit in mm

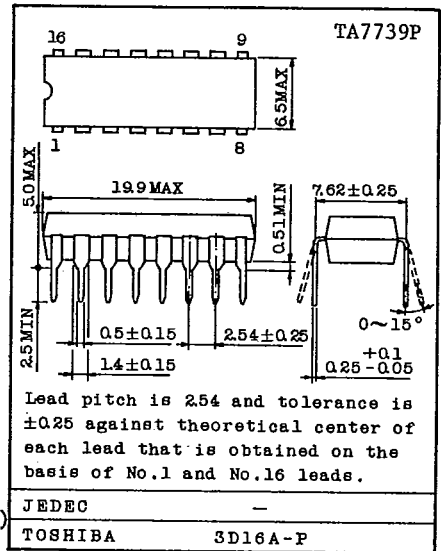

Unit in mm

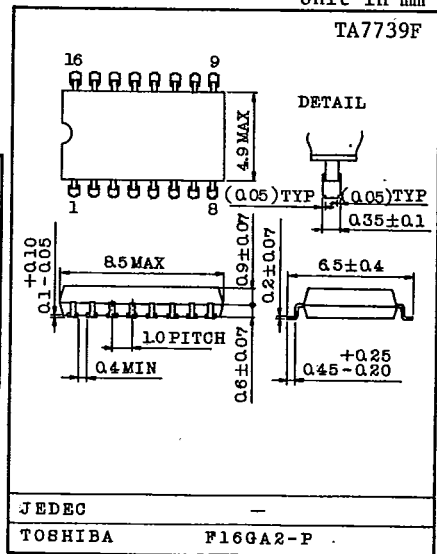

www.DataSheet4U.com

ELECTRICAL CHARACTERISTICS

(Unless otherwise specified, $V_{CC}=3V$, $f=1kHz$, $T_a=25^\circ C$, NAB-Circuit)

CHARACTERISTIC	SYMBOL	TEST CIR-CUIT	TEST CONDITION	MIN.	TYP.	MAX.	UNIT
Quiescent Current	ICCO	-	$V_{IN}=0V$	-	1.8	2.4	mA
Open Loop Voltage Gain	GVO	-		-	80	-	dB
Maximum Output Voltage	VOM	-	THD=0.5%	0.75	0.90	-	V_{rms}
Total Harmonic Distortion	THD	-	$V_O=0.32V_{rms}$	-	0.025	0.1	%
Equivalent Input Noise Voltage	VNI	-	$R_g=2.2k\Omega$, $BW=30Hz\sim 20kHz$ NAB ($G_V=40dB$)	-	0.9	1.7	μV_{rms}
Cross Talk F/R	C.T(F/R)	-	$V_O=0.32V_{rms}$, $R_g=2.2k\Omega$	55	65	-	dB
Cross Talk CH1/CH2	C.T	-	$V_O=0.32V_{rms}$, $R_g=2.2k\Omega$	55	65	-	dB
Ripple Rejection	R.R	-	$f=100Hz$, $V_R=0.32V_{rms}$	-	45	-	dB

TYPICAL DC VOLTAGE OF EACH TERMINAL

 $(V_{CC}=3V, T_a=25^\circ C, V_{IN}=0V, \text{ by Test Circuit})$

TERMINAL No.	1	2	3	4	5	6	7	8
DC-Voltage (V)	3	1.50	1.50	1.50	1.50	1.50	3.0/0	0

TERMINAL No.	9	10	11	12	13	14	15	16
DC-Voltage (V)	0.90	1.50	1.54	0/*	3.0/0	0/*	1.54	1.50

* : Floating

TA7739P / F

www.DataSheet4U.com

BLOCK DIAGRAM/TEST CIRCUIT

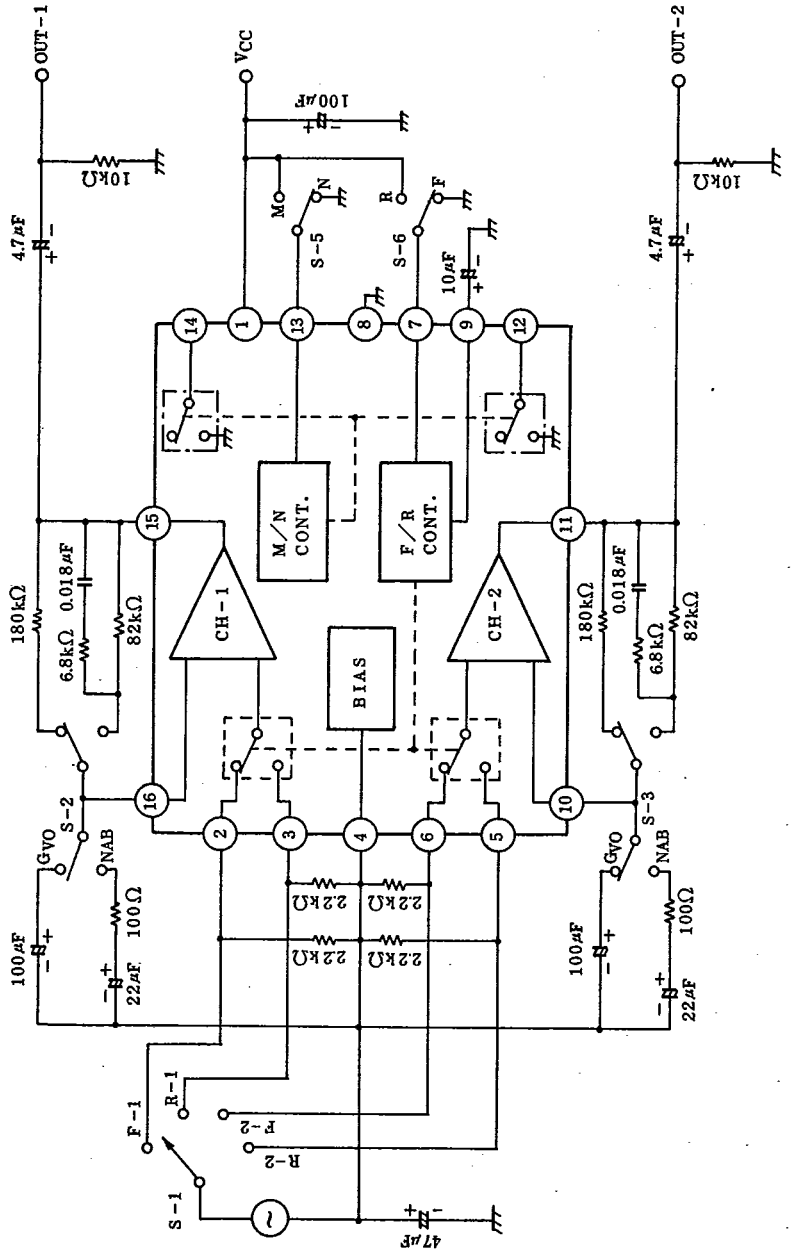

www.DataSheet4U.com

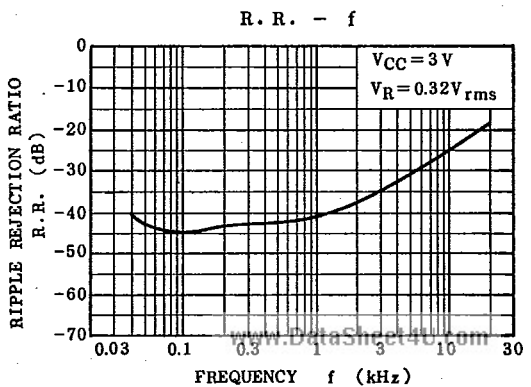
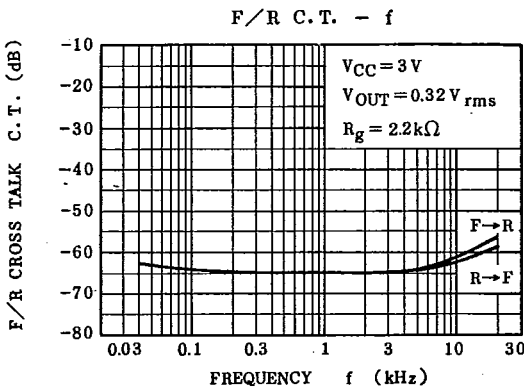
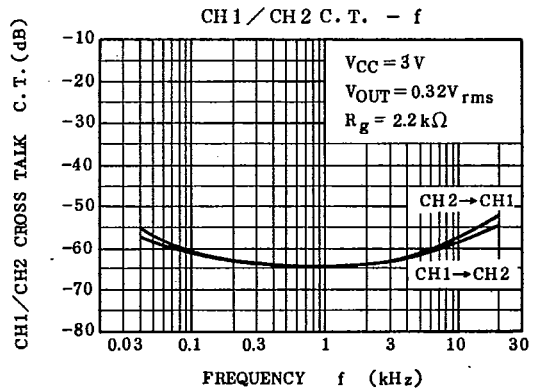
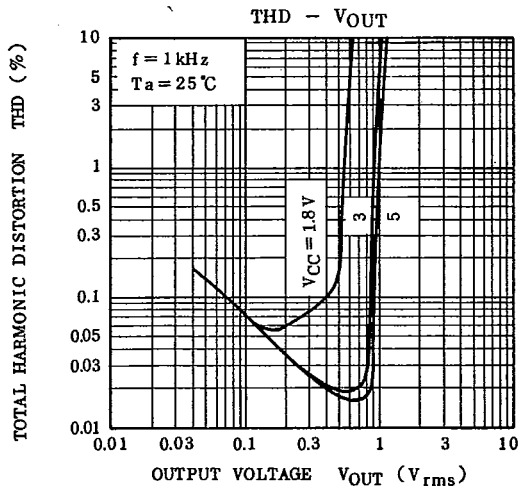
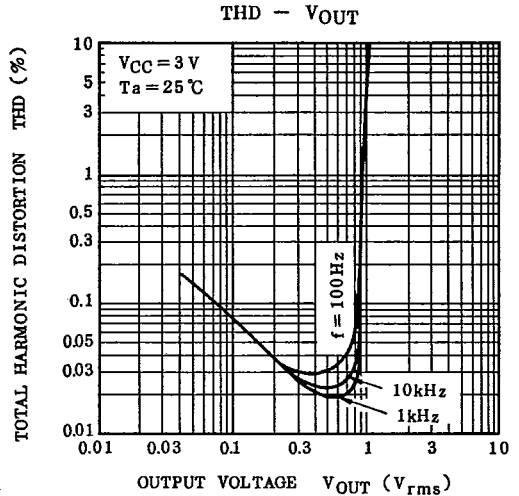
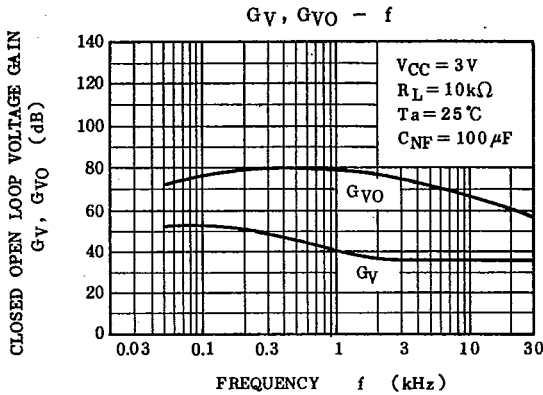

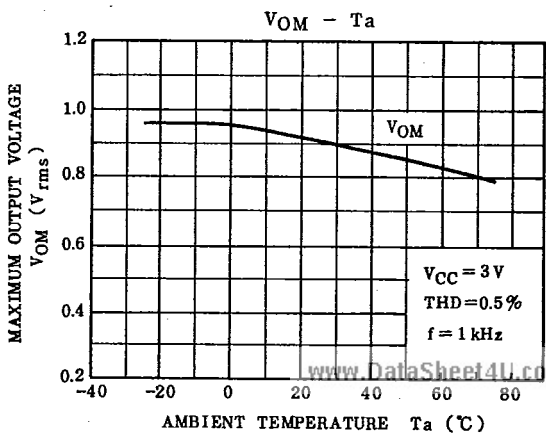
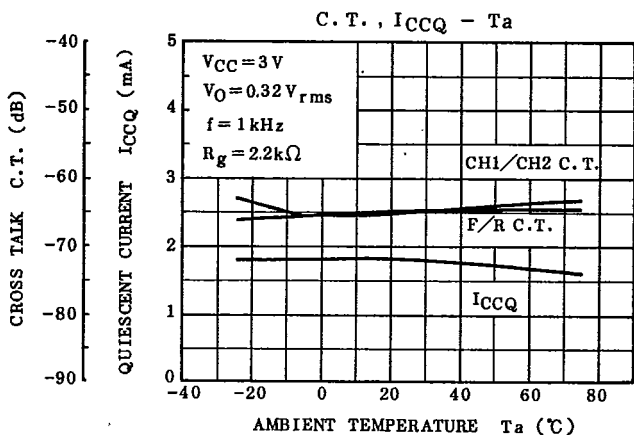
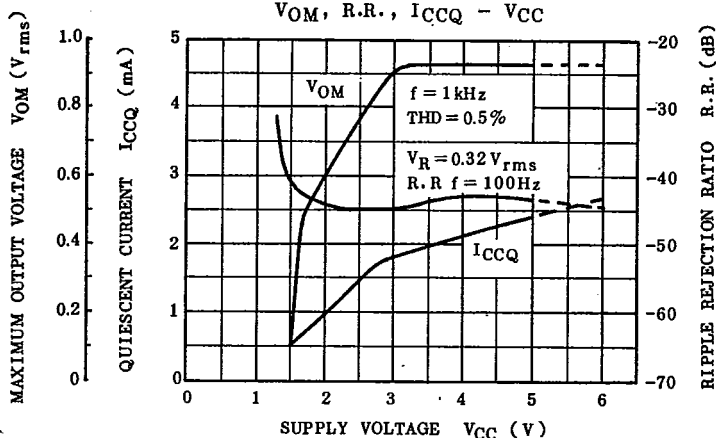

APPLICATION CIRCUIT

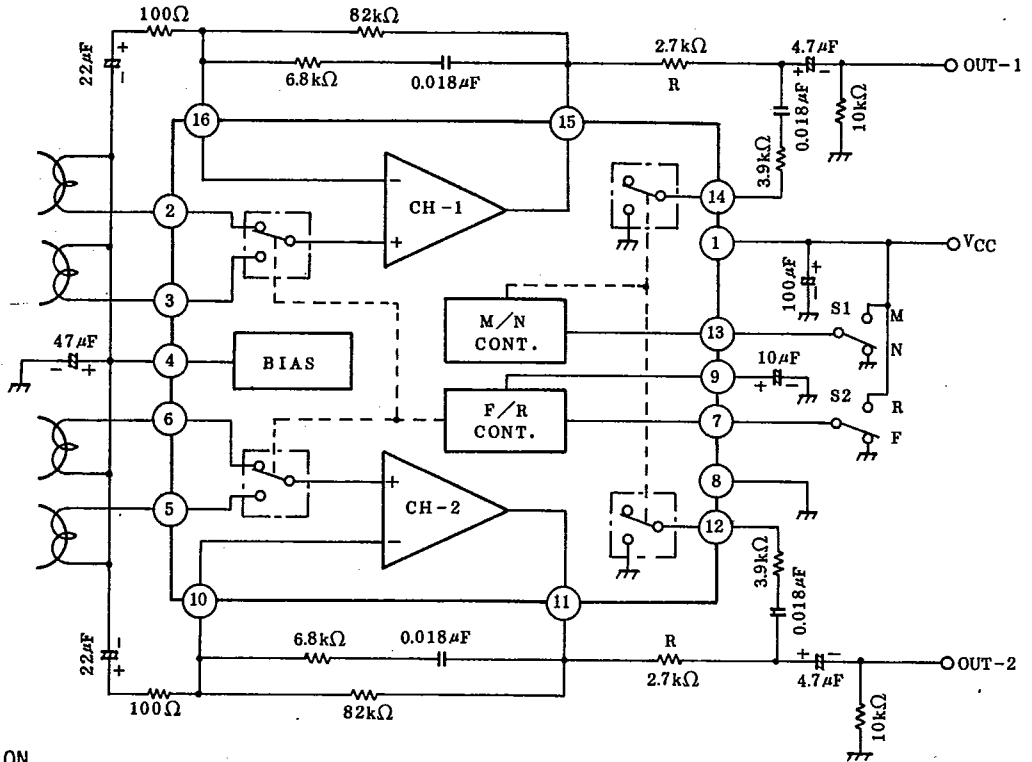

CAUTION

- Capacitive load should not be directly connected to output terminal to avoid instable operation.
- When closed loop voltage gain (G_v) is set below 40dB, a series resistor more than $1k\Omega$ connected to the output terminal is needed. Minimum closed loop voltage gain should be more than 21dB.
- About threshold level of S1 and S2, "H" level is above 0.9V, "L" level is below 0.3V.

