

## **FEATURES**

- \* Isolation voltage between input and output  $V_{iso} : 5,000V_{rms}$
- \* 6pin DIP zero-cross optoisolators triac driver output
- \* High repetitive peak off-state voltage  $V_{DRM} : \text{Min. } 600V$
- \* High critical rate of rise of off-state voltage  
(  $dv/dt : \text{MIN. } 600V / \mu s$  )
- \* Dual-in-line package :  
MOC3061, MOC3062, MOC3063
- \* Wide lead spacing package :  
MOC3061M, MOC3062M, MOC3063M
- \* Surface mounting package :  
MOC3061S, MOC3062S, MOC3063S
- \* Tape and reel packaging :  
TYPE I : MOC3061S-TA1, MOC3062S-TA1, MOC3063S-TA1

## **APPLICATIONS**

- \* AC Motor Drives
- \* AC Motor Starters
- \* E.M. Contactors
- \* Lighting Controls
- \* Solenoid/Valve Controls
- \* Solid State Relays
- \* Static Power Switches
- \* Temperature Controls

## OUTLINE DIMENSIONS

### Dual-in-line package :

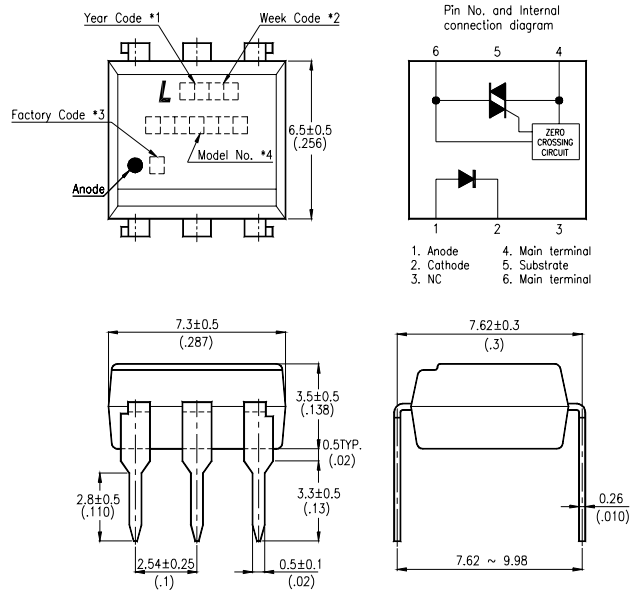

### Wide lead spacing package:

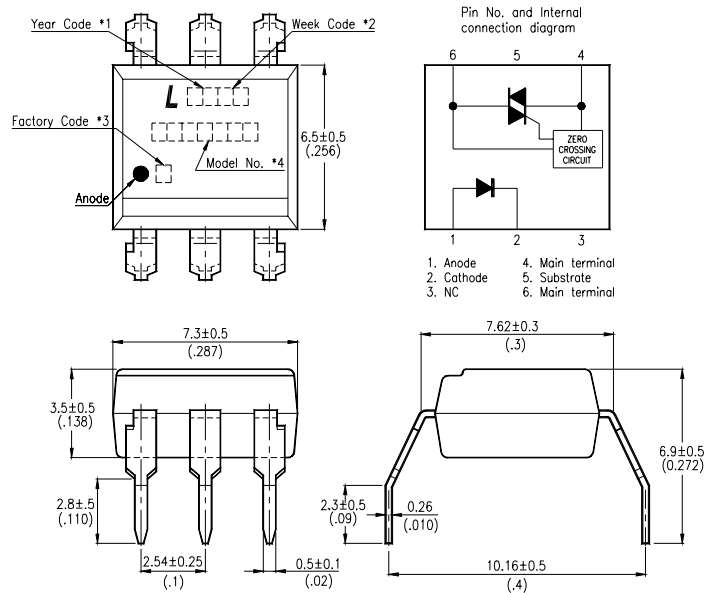

- \*1. Year date code.
- \*2. 2-digit work week.
- \*3. Factory identification mark shall be marked (Z : Taiwan, Y : Thailand, X : China).
- \*4. Model No.: MOC3061, MOC3062, MOC3063

## OUTLINE DIMENSIONS

Surface mounting package :

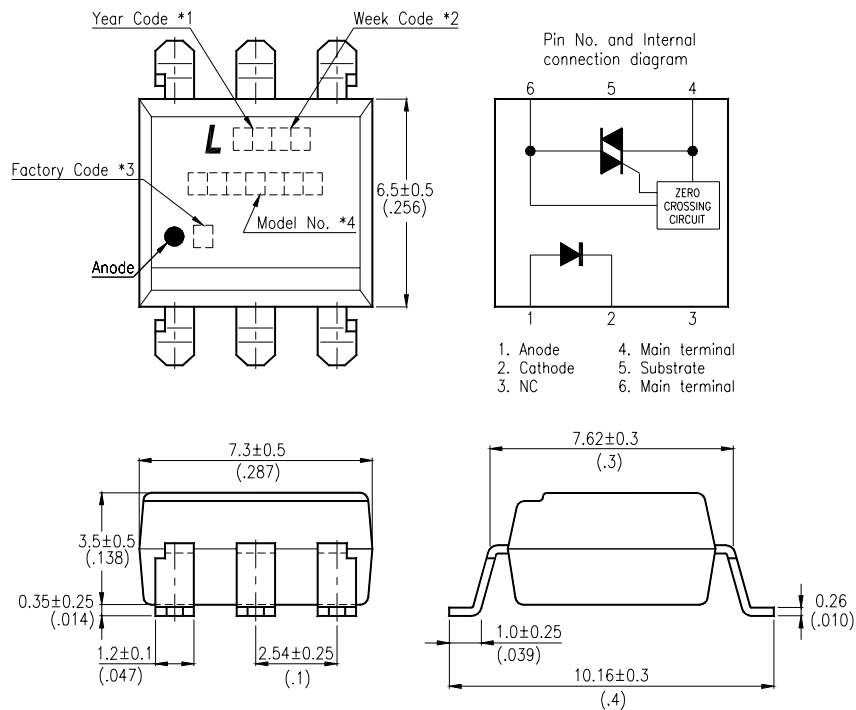

\*1. Year date code.

\*2. 2-digit work week.

\*3. Factory identification mark shall be marked (Z : Taiwan, Y : Thailand, X : China).

\*4. Model No.: MOC3061, MOC3062, MOC3063

## TAPING DIMENSIONS

**Tape and reel package ( TYPE I ):**

MOC3061S-TA1, MOC3062S-TA1, MOC3063S-TA1

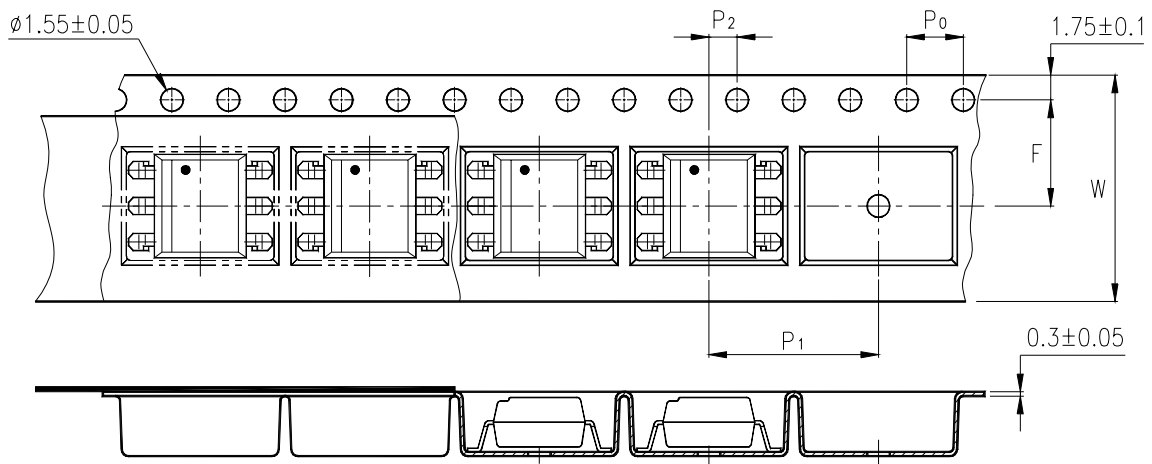

Description	Symbol	Dimensions in mm ( inches )
Tape wide	W	16 ± 0.3 ( .63 )
Pitch of sprocket holes	P <sub>0</sub>	4 ± 0.1 ( .15 )
Distance of compartment	F	7.5 ± 0.1 ( .295 )
Distance of compartment to compartment	P <sub>1</sub>	2 ± 0.1 ( .079 )
Distance of compartment to compartment	P <sub>1</sub>	12 ± 0.1 ( .472 )

**ABSOLUTE MAXIMUM RATING**

( Ta = 25°C )

PARAMETER		SYMBOL	RATING	UNIT
INPUT	Forward Current	I <sub>F</sub>	50	mA
	Reverse Voltage	V <sub>R</sub>	6	V
	Power Dissipation	P <sub>D</sub>	120	mW
OUTPUT	Off-State Output Terminal Voltage	V <sub>DRM</sub>	600	V
	Peak Repetitive Surge Current ( PW=100μs, 120pps )	I <sub>TSM</sub>	1	A
	Collector Power Dissipation	P <sub>C</sub>	150	mW
Total Power Dissipation		P <sub>tot</sub>	250	mW
*1	Isolation Voltage	V <sub>iso</sub>	5,000	V <sub>rms</sub>
Ambient Operating Temperature Range		T <sub>A</sub>	-40 ~ +100	°C
Storage Temperature Range		T <sub>stg</sub>	-55 ~ +150	°C
*2	Soldering Temperature	T <sub>L</sub>	260	°C

\*1. AC For 1 Minute, R.H. = 40 ~ 60%

Isolation voltage shall be measured using the following method.

- (1) Short between anode and cathode on the primary side and between collector, emitter on the secondary side.
- (2) The isolation voltage tester with zero-cross circuit shall be used.
- (3) The waveform of applied voltage shall be a sine wave.

\*2. For 10 Seconds

## ELECTRICAL - OPTICAL CHARACTERISTICS

( Ta = 25°C )

PARAMETER		SYMBOL	MIN.	TYP.	MAX.	UNIT	CONDITIONS
INPUT	Forward Voltage	$V_F$	—	1.2	1.4	V	$I_F=20\text{mA}$
	Reverse Current	$I_R$	—	0.05	10	$\mu\text{A}$	$V_R=6\text{V}$
OUTPUT	*1 Peak Blocking Current, Either Direction	$I_{\text{DRM1}}$	—	—	500	nA	$V_{\text{DRM}} = 600\text{V}$
	Peak On-State Voltage, Either Direction	$V_{\text{TM}}$	—	—	3.0	V	$I_{\text{TM}}=100\text{ mA Peak}$
	*2 Critical rate of Rise of Off-State Voltage	dv/dt	600	1500	—	V/ $\mu\text{s}$	
COUPLED	*3 Led Trigger Current, Current Required to Latch Output, Either Direction	MOC3061	—	—	15	mA	Main Terminal Voltage = 3V
		MOC3062	—	—	10		
		MOC3063	—	—	5		
	Holding Current, Either Direction	$I_H$	—	400	—	$\mu\text{A}$	
Turn-On Time	$T_{\text{ON}}$	—	8	20	$\mu\text{s}$	$V_P=9\text{V}$ , $I_F=20\text{mA}$ $R_L = 100\Omega$	
ZERO CROSSING	Inhibit Voltage	$V_{\text{INH}}$	—	5	20	Volts	$I_F=\text{Rated } I_{\text{FT}}$ , MT1-MT2 Voltage above which device will not trigger.
	Leakage in Inhibited State	$I_{\text{DRM2}}$	—	—	500	$\mu\text{A}$	$I_F = \text{Rated } I_{\text{FT}}$ , Rated $V_{\text{DRM}}$ , Off State

\*1 Test voltage must be applied within dv/dt rating.

\*2 This is static dv/dt. Commutating dv/dt is a function of the load-driving thyristor(s) only.

\*3 All devices are guaranteed to trigger at an  $I_F$  value less than or equal to max  $I_{\text{FT}}$ . Therefore, recommended operating  $I_F$  lies between max  $I_{\text{FT}}$  (15 mA for MOC3061, 10mA for MOC3062, 5mA for MOC3063) and absolute max  $I_F$  (50mA)

## CHARACTERISTICS CURVES

Fig.1 Forward Current vs. Ambient Temperature

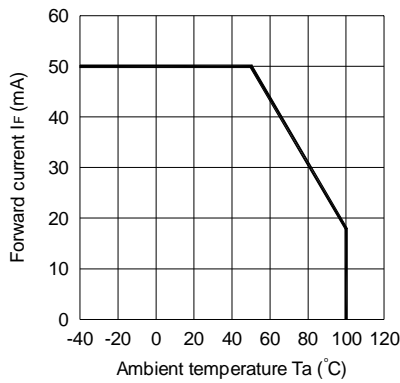

Fig.2 On-state Current vs. Ambient Temperature

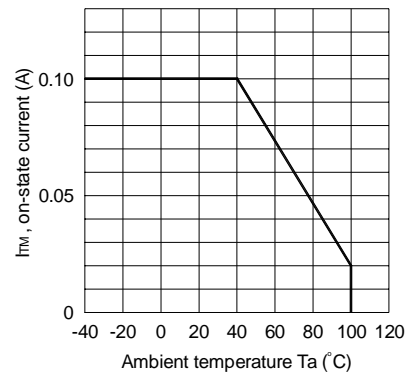

Fig.3 Minimum Trigger Current vs. Ambient Temperature

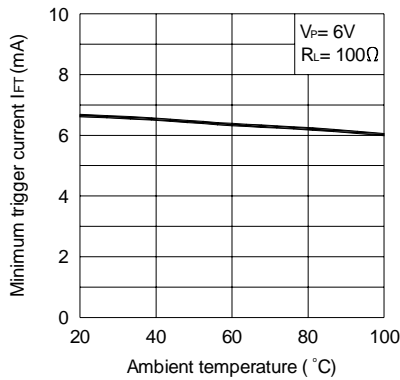

Fig.4 Forward Current vs. Forward Voltage

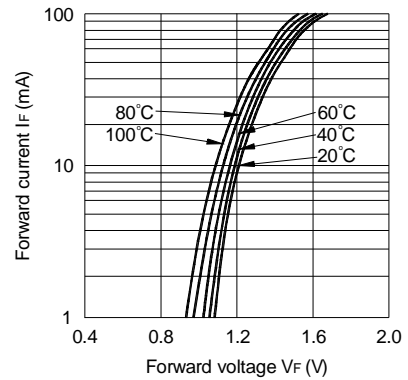

Fig.5 On-state Voltage vs. Ambient Temperature

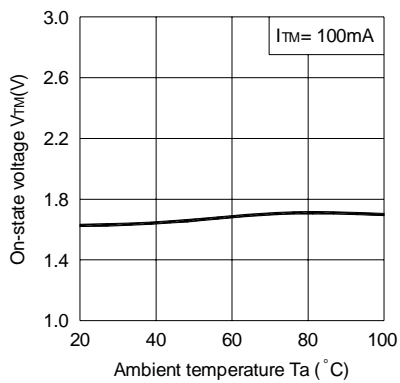
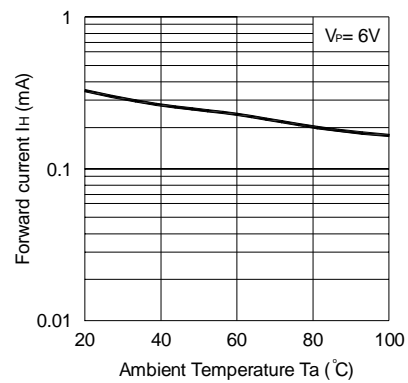

Fig.6 Holding Current vs. Ambient Temperature



## CHARACTERISTICS CURVES

Fig.7 Turn-on Time vs. Forward Current

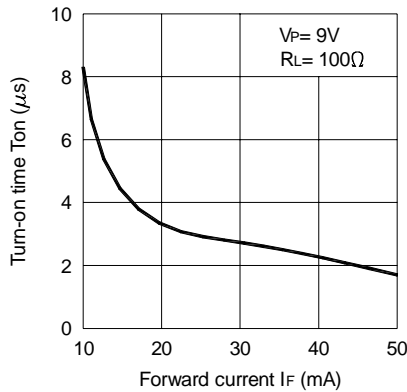

Fig.8 Repetitive Peak Off-state Current vs. Temperature

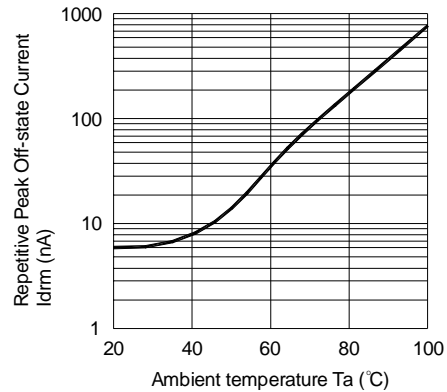
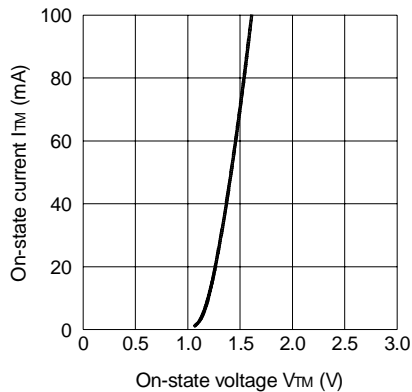
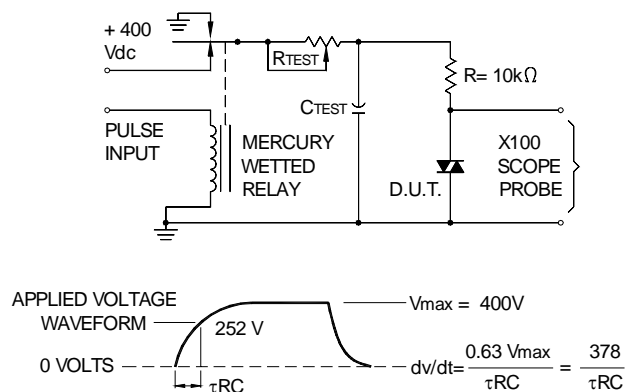

Fig.9 On-state Current vs. On-state Voltage



Static dv/dt Test Circuit



## RECOMMENDED FOOT PRINT PATTERNS (MOUNT PAD)

