



# LB1854M

## Three-Phase Brushless Motor Driver IC

### Overview

The LB1854M is a three-phase brushless motor driver IC and is optimal, in particular, for driving VCR capstan and drum motors.

### Features

- 120° voltage linear drive technique
- The LB1854M soft switching scheme allows smaller external capacitors to be used (e.g., chip capacitors).
- Built-in thermal-shutdown function
- Built-in overcurrent protection circuit
- Built-in FG amplifiers (operational amplifier and Schmitt amplifier)
- Control start voltage set by an external voltage
- The output current feedback level can be changed by changing the control gain to one of two levels.

### Package Dimensions

unit: mm

#### 3073A-MFP30S

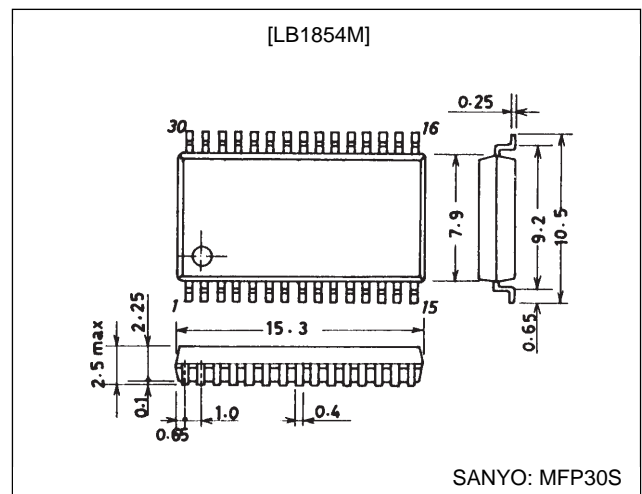

### Specifications

#### Absolute Maximum Ratings at $T_a = 25^\circ\text{C}$

Parameter	Symbol	Conditions	Ratings	Unit
Maximum supply voltage	$V_{CC1 \text{ max}}$		20	V
	$V_{CC2 \text{ max}}$		7.0	V
Applied output voltage	$V_{OU, v, w}$		22	V
Maximum output current	$I_{OUT \text{ max}}$		1.5	A
Allowable power dissipation	$P_d \text{ max}$		1.05	W
Operating temperature	$T_{opr}$		-20 to +75	$^\circ\text{C}$
Storage temperature	$T_{stg}$		-55 to +150	$^\circ\text{C}$

#### Allowable Operating Ranges at $T_a = 25^\circ\text{C}$

Parameter	Symbol	Conditions	Ratings	Unit
Supply voltage	$V_{CC1}$		5 to 18	V
	$V_{CC2}$		4.3 to 6.5	V

**SANYO Electric Co., Ltd. Semiconductor Business Headquarters**

TOKYO OFFICE Tokyo Bldg., 1-10, 1 Chome, Ueno, Taito-ku, TOKYO, 110 JAPAN

## LB1854M

### Electrical Characteristics at $T_a = 25^\circ\text{C}$ , $V_{CC1} = 12\text{ V}$ , $V_{CC2} = 5\text{ V}$

Parameter	Symbol	Conditions	min	typ	max	Unit
Current drain	$I_{CC1}$	$V_C = 0\text{ V}$ , $R_L = \infty$		17	30	mA
	$I_{CC2}$	$V_C = 0\text{ V}$		6.5	9.5	mA
[Drive Block]						
Output saturation voltage	$V_O(\text{sat}) 1$	$I_{OUT} = 0.5\text{ A}$ , sink + source		1.6	2.2	V
	$V_O(\text{sat}) 2$	$I_{OUT} = 1.0\text{ A}$ , sink + source		2.0	3.0	V
Output TRS breakdown voltage	$V_O(\text{sus})$	$I_{OUT} = 20\text{ mA}^*$	20			V
Output resting potential	$V_{OQ}$	$V_C = 0\text{ V}$	5.7	6.0	6.3	V
Hall amplifier input offset voltage	$V_H$ offset		-5		+5	mV
Hall amplifier input bias current	$I_H$ bias			1	5	$\mu\text{A}$
Hall amplifier common mode input voltage range	$V_H$ ch		1.3		2.2	V
Hall input/output voltage gain	$GV_{HO}$		43	46	49	dB
[Control Block]						
Control output drive gain	$GV_{CO1}$	High gain	37	40	43	dB
	$GV_{CO2}$	Low gain	31	34	37	dB
Control output CH difference	$\Delta GV_{CO}$		-2		+2	dB
Control start voltage	$V_{CTH}$	When $V_{OUTp-p} = 2\text{ V}$		2.5		V
Gain control switching high level			4		5	V
Gain control switching middle level		Middle level when the input is open	2		3	V
Gain control switching low level			0		1	V
[FG Amplifier]						
FG amplifier input offset voltage	$V_{FG}$ offset		-8		+8	mV
Open-loop voltage gain	$GV_{FG}$	$f = 1\text{ kHz}$		60		dB
Source output saturation voltage	$V_{FG\text{ OU}}$	$I_O = 2\text{ mA}$	37			V
Sink output saturation voltage	$V_{FG\text{ OD}}$	$I_O = -2\text{ mA}$			1.3	V
Common-mode signal rejection ratio	CHR	*		80		dB
FG amplifier common-mode input voltage range	$V_{FG\text{ CH}}$		0		3.5	V
Phase margin		*		20		Deg
Schmitt hysteresis	$\Delta V_{sh1}$	$FG_{OUT2}$ : High to low		22		mV
	$\Delta V_{sh2}$	$FG_{OUT2}$ : Low to high		22		mV
Schmitt input voltage range	$V_{shCH}$		0.7		3.5	V
[Thermal Shutdown]						
Operating temperature	TSD	*	150	180	210	$^\circ\text{C}$
Hysteresis	$\Delta TSD$	*		15		$^\circ\text{C}$

Note: \* Items marked with an asterisk are design target values and are not measured.

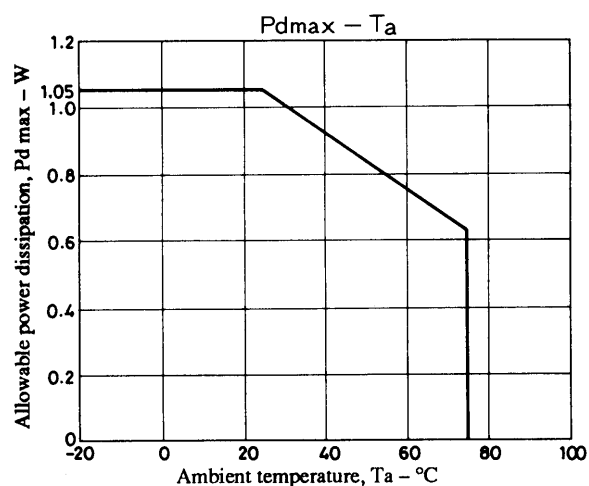

# LB1854M

## Pin Assignment

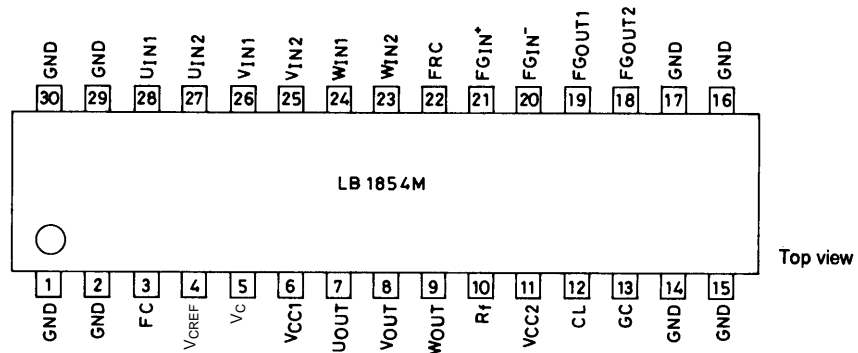

## Block Diagram

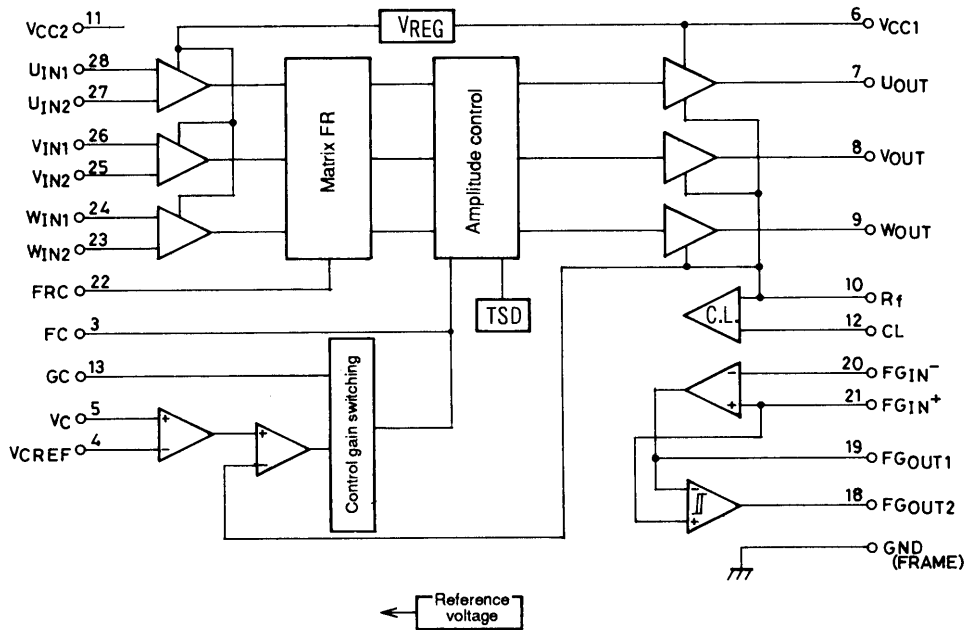

## Sample Application Circuit

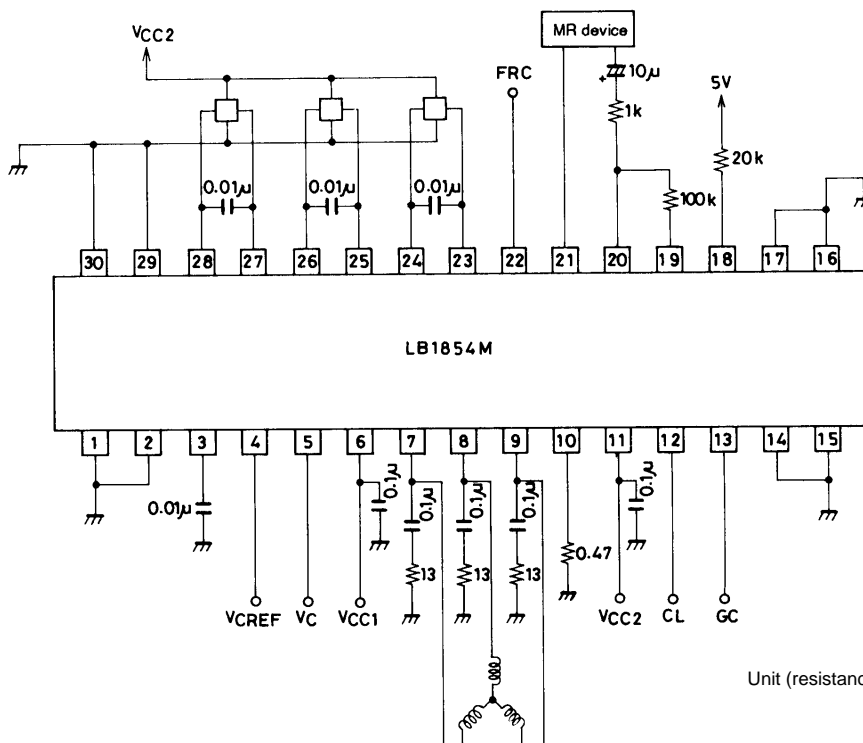

Unit (resistance: Ω, capacitance: F)

## LB1854M

### Truth Table

	Source Sink	Input			Forward and reverse control F/RC
		U	V	W	
1	W phase → V phase	H	H	L	L
	V phase → W phase				H
2	W phase → U phase	H	L	L	L
	U phase → W phase				H
3	V phase → W phase	L	L	H	L
	W phase → V phase				H
4	U phase → V phase	L	H	L	L
	V phase → U phase				H
5	V phase → U phase	H	L	H	L
	U phase → V phase				H
6	U phase → W phase	L	H	H	L
	W phase → U phase				H

Input high: Phase 1 is 0.2 V or more higher than the corresponding phase 2 for each phase input.

Low: Phase 1 is 0.2 V or more lower than the corresponding phase 2 for each phase input.

Forward and reverse control high: 2.3 V to  $V_{CC1}$

Low: 0 V to 0.7 V

### Pin Functions

Unit (resistance:  $\Omega$ )

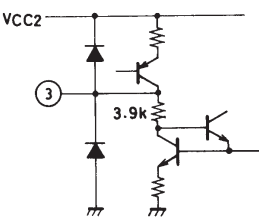
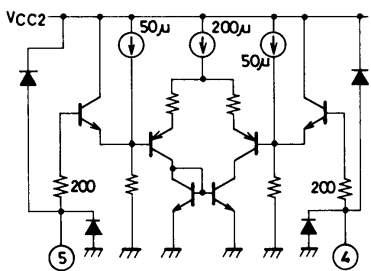
Pin No.	Symbol	Pin voltage	Equivalent circuit	Function
1, 2, 14, 15, 16, 17, 29, 30	FRAME (GND)			Ground for all circuits except the outputs
3	FC			The gain frequency characteristics can be lowered by connecting a capacitor between this pin and ground to prevent oscillation.
4 5	$V_{C REF}$ $V_C$	1.5 V min $V_{CC2}$ max 0 V min $V_{CC2}$ max		Speed control The LB1854M implements a voltage control scheme in which the output voltage is controlled by the pin 5 voltage. The pin 4 voltage determines the control start voltage.
6	$V_{CC1}$	5 to 18 V		Power supply that provides the drive outputs

## LB1854M

Continued from preceding page.

Unit (resistance:  $\Omega$ )

Pin No.	Symbol	Pin voltage	Equivalent circuit	Function
7 8 9	$U_{OUT}$ $V_{OUT}$ $W_{OUT}$			Output pins
10	$R_f$			Output transistor ground Feedback can be applied to the control amplifier by inserting resistor between this pin and GND and detecting the output current as a voltage. The overcurrent protection circuit (current limiter) operates by detecting the voltage on this pin.
11	$V_{CC2}$	4.3 to 6.5 V		Power supply provided to all blocks other than the output block This voltage must be stabilized so that no ripple or other noise is present.
12	CL	0 V min $V_{CC2}$ max		The current limiter operates when the $R_f$ pin reaches the same potential as pin 12. The pin 12 potential is set up externally.
13	GC	0 V min $V_{CC2}$ max		Control input to output gain switching pin High level (4 to 5 V): 34 dB Middle level (2 to 3 V) or open: 40 dB (low speed): 34 dB (high speed) Low level (0 to 1 V): 40 dB However, note that this applies when $V_{CC2}$ is 5 V.
18	$FG_{OUT2}$			FG Schmitt amplifier output
19	$FG_{OUT1}$			FG amplifier output

Continued on next page.

## LB1854M

Continued from preceding page.

Unit (resistance:  $\Omega$ )

Pin No.	Symbol	Pin voltage	Equivalent circuit	Function
20 21	FG <sub>IN-</sub> FG <sub>IN+</sub>	0 V min 3.5 V max (when V <sub>CC2</sub> is 5 V)		FG signal input
22	FRC	High: 2.3 V min Low: 0.7 V max		Motor forward/reverse control pin Low level (0.7 V or lower): forward High level (2.3 V or higher): reverse
23 24 25 26 27 28	W <sub>IN2</sub> W <sub>IN1</sub> V <sub>IN2</sub> V <sub>IN1</sub> U <sub>IN2</sub> U <sub>IN1</sub>	1.4 V min 2.0 V max		W phase Hall sensor input Logic high is the W <sub>IN1</sub> > W <sub>IN2</sub> state. V phase Hall sensor input Logic high is the V <sub>IN1</sub> > V <sub>IN2</sub> state. U phase Hall sensor input Logic high is the U <sub>IN1</sub> > U <sub>IN2</sub> state.

- No products described or contained herein are intended for use in surgical implants, life-support systems, aerospace equipment, nuclear power control systems, vehicles, disaster/crime-prevention equipment and the like, the failure of which may directly or indirectly cause injury, death or property loss.
- Anyone purchasing any products described or contained herein for an above-mentioned use shall:
  - ① Accept full responsibility and indemnify and defend SANYO ELECTRIC CO., LTD., its affiliates, subsidiaries and distributors and all their officers and employees, jointly and severally, against any and all claims and litigation and all damages, cost and expenses associated with such use:
  - ② Not impose any responsibility for any fault or negligence which may be cited in any such claim or litigation on SANYO ELECTRIC CO., LTD., its affiliates, subsidiaries and distributors or any of their officers and employees jointly or severally.
- Information (including circuit diagrams and circuit parameters) herein is for example only; it is not guaranteed for volume production. SANYO believes information herein is accurate and reliable, but no guarantees are made or implied regarding its use or any infringements of intellectual property rights or other rights of third parties.

This catalog provides information as of November, 1997. Specifications and information herein are subject to change without notice.

This datasheet has been download from:

[www.datasheetcatalog.com](http://www.datasheetcatalog.com)

Datasheets for electronics components.