

GL7445

BIDIRECTIONAL MOTOR DRIVER

Description

The GL7445 is a bidirectional motor driver IC. Since it has a 2 input logic circuit and performs the functions of bidirectional driving and braking, it is capable of direct driving 6V, 9V, 12V motors. The output voltage can be varied by using an external zener diode.

Features

- Built-in Braking Function
- Built-in Element to Absorb Dash Current of Motor
- Input Connectable Direct to MOS LSI
- Output Voltage Variable by Use of External Zener Diode.

Absolute Maximum Ratings ($T_A=25^\circ\text{C}$)

Supply Voltage	$V_{CC\text{ max}}$	18 V
Input Voltage	V_{IN}	-0.3 ~ V_{CC} V
Output Current	$I_{out(peak)}$	± 1.6 A
Power Dissipation	P_D	2.2 W
Operating Temperature	T_{OPR}	-25 ~ 75 $^\circ\text{C}$
Storage Temperature	T_{STG}	-55 ~ 125 $^\circ\text{C}$

Pin Configuration

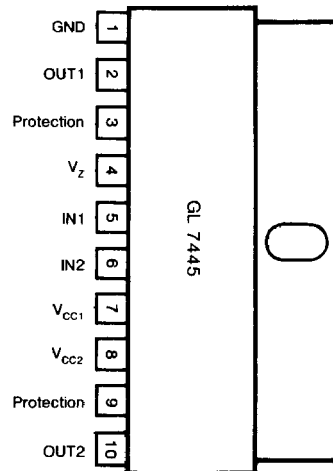

Block Diagram

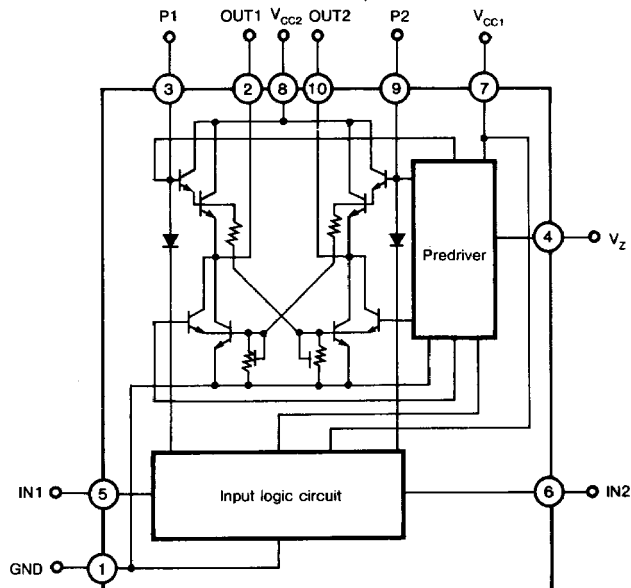

Electrical Characteristics: $T_A=25^\circ\text{C}$, $V_{CC}=12\text{V}$ (unless otherwise specified)

PARAMETER	SYMBOL	CONDITIONS	MIN	TYP	MAX	UNIT
Input Threshold Voltage	V_{TH}	$R_L = \infty$	1.1	1.3	1.5	V
Input-On Current	I_{IN}	$R_L = \infty$	—	10	15	μA
Output Voltage	V_O	$R_L = 60\Omega$ $V_Z = 7.4\text{V}$	6.6	7.2	7.4	V
Output Leakage Current	I_{OL}	Pin 5,6: GND $R_L = \infty$	—	0.01	1.0	mA
Quiescent Current	I_{CC}	Pin 5,6: GND $R_L = \infty$	3	6	10	mA
Saturation Voltage 1 _(UPP)	V_{SU1}	$I_{OUT} = 300\text{mA}$	—	1.9	2.3	V
Saturation Voltage 2 _(UPP)	V_{SU2}	$I_{OUT} = 500\text{mA}$	—	1.9	2.3	V
Saturation Voltage 1 _(LOW)	V_{SL1}	$I_{OUT} = 300\text{mA}$	—	0.25	0.5	V
Saturation Voltage 2 _(LOW)	V_{SL2}	$I_{OUT} = 500\text{mA}$	—	0.4	0.65	V

Logic Table

Input		Output		Function
IN1	IN2	OUT1	OUT2	
0	0	0	0	Braking
1	0	1	0	Forward (reverse) drive
0	1	0	1	Reverse (forward) drive
1	1	0	0	Braking

Input level
 1: 2.0V or more
 0: 0.7V or less

Typical Performance Curves

$I_{CC} \cdot V_{CC}$

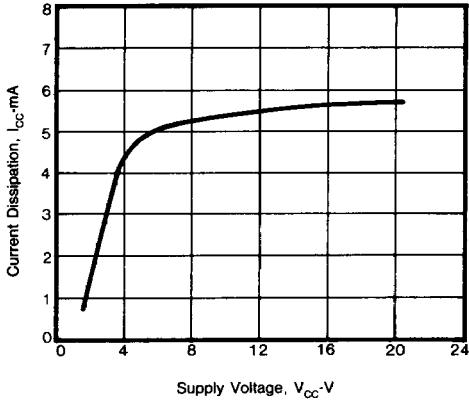

$V_{sat1} \cdot I_O$

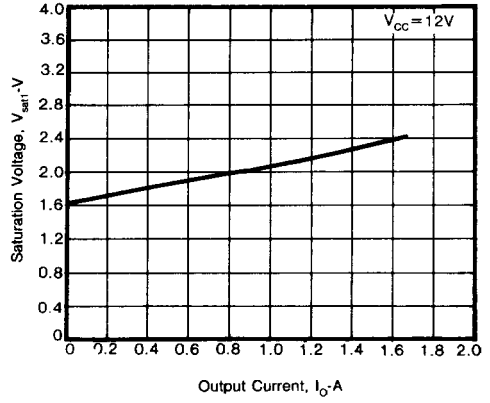

$I_{CC} \cdot T_A$

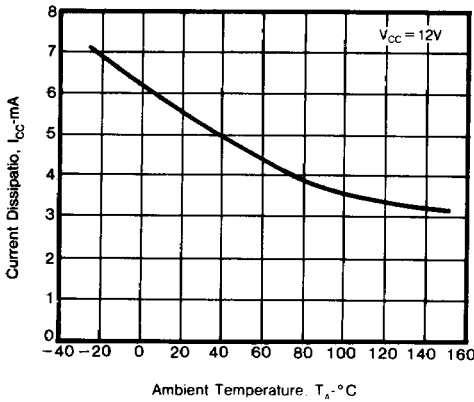

$V_{sat2} \cdot I_O$

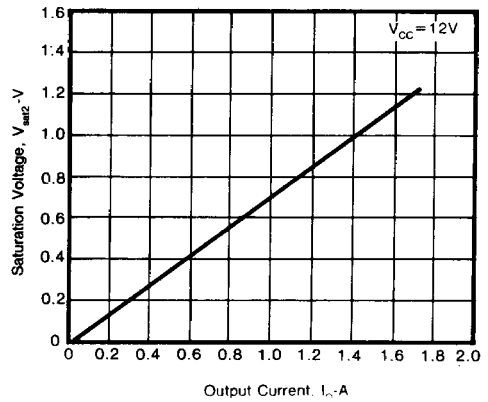

$V_O \cdot V_Z$

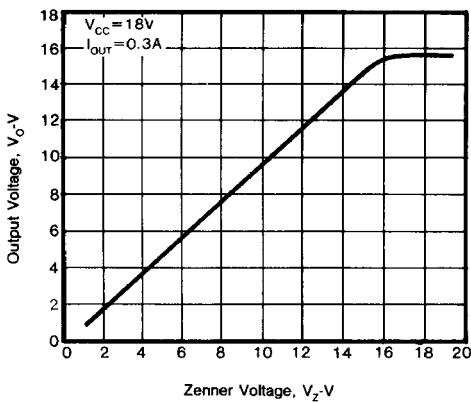

$P_d \text{ max} \cdot T_A$

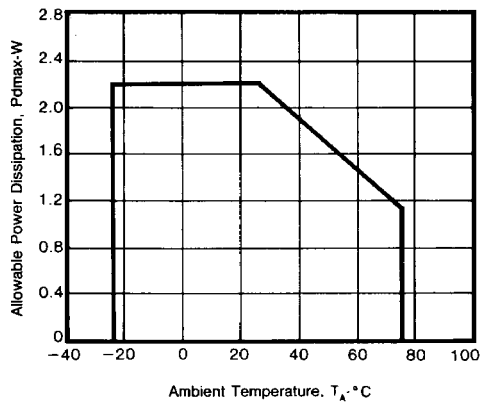

Test Circuit

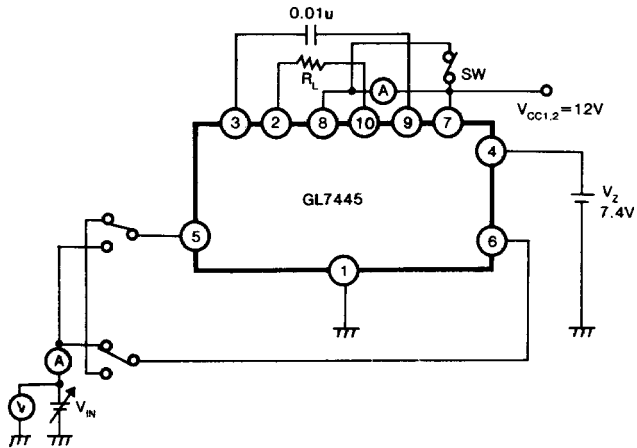

Application Circuit

