

STRUCTURE                      Silicon monolithic integrated circuits

PRODUCT SERIES              2-in-1 motor driver for VTR

TYPE                                **BD6903EFV**

FUNCTION                        • VTR cylinder motor driver (Sensorless 3-phase full-wave soft switching drive system)  
    • VTR loading motor driver

○Absolute maximum ratings (Ta=25°C)

Parameter	Symbol	Limit	Unit
Supply voltage	VCC	7	V
	VM	15	V
	VG	20	V
Power dissipation	Pd	1000 <sup>*1</sup>	mW
Operating temperature range	Topr	-20~+75	°C
Storage temperature range	Tstg	-55~+150	°C
Maximum output current (cylinder block)	Iomax1	800 <sup>*2</sup>	mA
Maximum output current (loading block)	Iomax2	1000 <sup>*2</sup>	mA
Junction temperature	Tjmax	+150	°C

<sup>\*1</sup> 70mm × 70mm × 1.6mm glass epoxy board. Derating is done at 8.0mW/°C for operating above Ta=25°C.

<sup>\*2</sup> Do not, however exceed Pd, ASO and Tjmax=150°C.

○Recommended operating conditions (Ta= -25~+75°C)

Parameter	Symbol	Min	Typ	Max	Unit
Supply voltage	VCC	4.5	5	5.5	V
	VM	9	12	13.5	V
	VG	VM+3	17	19	V
UIN, VIN, WIN in-phase input voltage range	VBEMFD	0	-	VM	V
PG amp in-phase input voltage range	VPD	1.5	-	3.0	V

This product described in this specification isn't judged whether it applies to COCOM regulations.

Please confirm in case of export.

This product isn't designed for protection against radioactive rays.

○Electrical characteristics (Unless otherwise specified, Ta=25°C, VCC=5V, VM =12V, VG=17V)

Parameter	Symbol	Limit			Unit	Conditions
		Min	Typ	Max		
<b>Overall</b>						
VCC total supply current	ICC	-	9.2	14.2	mA	
VM total supply current 1	IM1	-	1.4	2.8	mA	LIN=H or L
VM total supply current 2	IM2	-	1.4	2.8	mA	LIN=M
<b>Output</b>						
High-side output saturation voltage	VOH	-	0.4	0.8	V	Io=-400mA
Low-side output saturation voltage	VOL	-	0.3	0.6	V	Io=400mA
<b>Torque reference</b>						
EC input bias current	IEC	-	0.5	2	μA	
Torque reference start voltage	VECR	2.35	2.5	2.65	V	
Torque reference I/O gain	Gio	0.72	0.99	1.28	A/V	EC=2.6V-2.7V Gain output (HLM) RRNF = 0.5Ω
<b>Soft switch</b>						
CT1, CT2 charge current	ICTD	-50	-35	-25	μA	
CT1, CT2 discharge current	ICTI	27	40	56	μA	
High CT1, CT2 clamp voltage	VCTH	4.4	4.7	-	V	
Low CT1, CT2 clamp voltage	VCTL	0.8	1.0	1.3	V	
<b>Startup control logic</b>						
CST charge current	ICSTD	-20	-14	-6	μA	
CST discharge current	ICSTI	2	6	10	μA	
High CST clamp voltage	VCSTH	2.4	2.8	3.3	V	
Low CST clamp voltage	VCSTL	0.8	1.0	1.3	V	
<b>PG amp</b>						
Input bias current	IPG-	-	0.1	0.25	μA	PG=GND
DC bias voltage	VPG	2.25	2.5	2.75	V	PG=PGOUT
Voltage gain 1	AV1	17.5	18.8	-	dB	f=1KHz
High output voltage	VOHP	3.4	3.75		V	IOH=-1mA
Low output voltage	VOLP	-	1.2	1.6	V	IOL=1mA
<b>HYS amp</b>						
Hysteresis width	VHYS	-75	-100	-125	mV	
<b>PFGpin</b>						
High output voltage	VPFHP	4.5	-	-	V	IO=-10 μA
Middle output voltage	VPFMP	2.25	-	2.75	V	IO=±10 μA
Low output voltage	VPFGL	-	-	0.5	V	IO=10 μA
<b>Loading</b>						
High-level LIN input	VLINH	3.5	-	-	V	Loading: Forward rotation
Middle-level LIN input	VLINM	2.35	-	2.65	V	Loading: Brake
Low-level LIN input	VLINL	-	-	1.5	V	Loading: Reverse rotation
LIN bias voltage	VLINB	2.35	2.5	2.65	V	
Output saturation voltage	VCE	-	0.3	0.6	V	IO=200mA, total of output transistor high-side and low-side voltage

※Source currents are treated as negative while sinking currents are treated as positive.

○Package outline

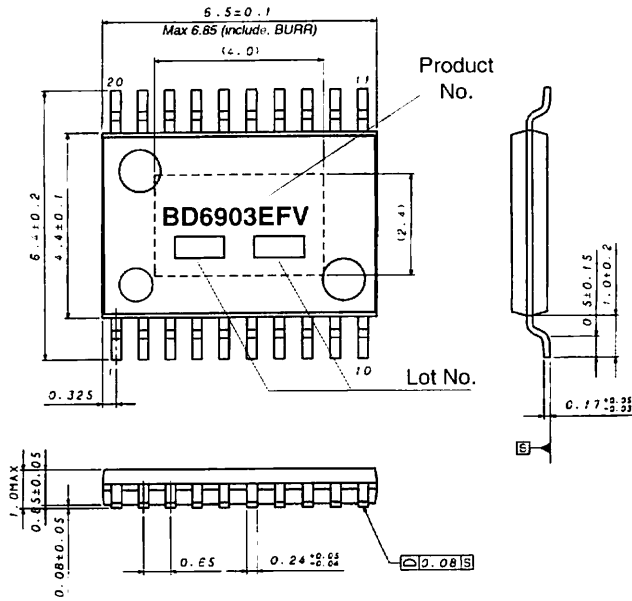

HTSSOP-B20 (Unit:mm)

○Block diagram

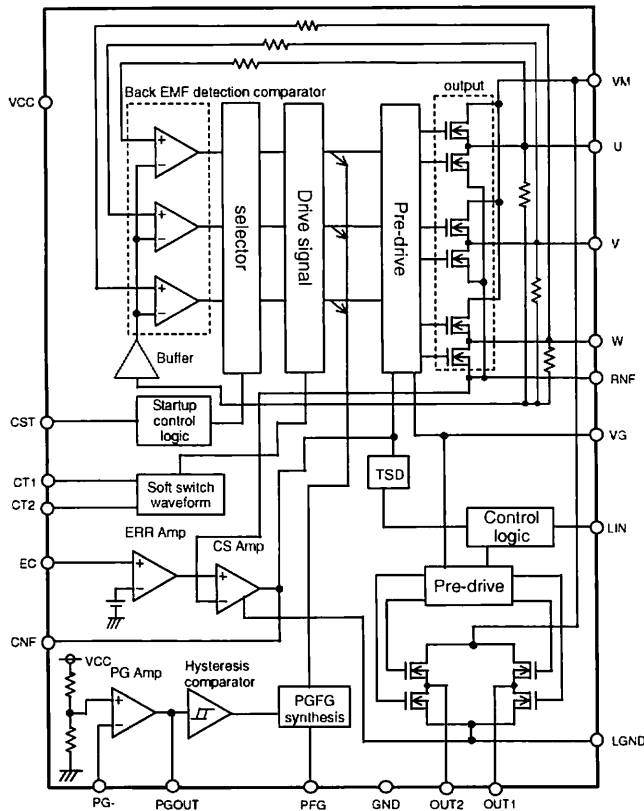

○Pin No. / Pin name

Pin No.	Pin name
1	GND
2	LIN
3	EC
4	CT1
5	CT2
6	CST
7	CNF
8	PGOUT
9	PG-
10	VCC
11	W
12	V
13	RNF
14	U
15	VG
16	VM
17	OUT1
18	OUT2
19	LGND
20	PFG

○Operation Notes

(1) Absolute maximum ratings

Use of the IC in excess of absolute maximum ratings such as the applied voltage or operating temperature range (Topr) may result in IC damage. Assumptions should not be made regarding the state of the IC (short mode or open mode) when such damage is suffered. The implementation of a physical safety measure such as a fuse should be considered when use of the IC in a special mode where the absolute maximum ratings may be exceeded is anticipated.

(2) Power supply lines

Regenerated current may flow as a result of the motor's back electromotive force. Insert capacitors between the power supply and ground pins to serve as a route for regenerated current. Determine the capacitance in full consideration of all the characteristics of the electrolytic capacitor, because the electrolytic capacitor may lose some capacitance at low temperatures. If the connected power supply does not have sufficient current absorption capacity, regenerative current will cause the voltage on the power supply line to rise, which combined with the product and its peripheral circuitry may exceed the absolute maximum ratings. It is recommended to implement a physical safety measure such as the insertion of a voltage clamp diode between the power supply and GND pins.

(3) Ground potential

Ensure a minimum GND pin potential in all operating conditions.

(4) Setting of heat

Use a thermal design that allows for a sufficient margin in light of the power dissipation (Pd) in actual operating conditions. This IC exposes its frame of the backside of package. Note that this part is assumed to use after providing heat dissipation treatment to improve heat dissipation efficiency. Try to occupy as wide as possible with heat dissipation pattern not only on the board surface but also the backside.

(5) Actions in strong magnetic field

Use caution when using the IC in the presence of a strong magnetic field as doing so may cause the IC to malfunction.

(6) ASO

When using the IC, set the output transistor for the motor so that it does not exceed absolute maximum ratings or ASO.

(7) Thermal shutdown circuit

This IC incorporates a TSD (thermal shutdown) circuit (TSD circuit). If the temperature of the chip reaches the following temperature, the motor coil output will be opened. The thermal shutdown circuit (TSD circuit) is designed only to shut the IC off to prevent runaway thermal operation. It is not designed to protect the IC or guarantee its operation. Do not continue to use the IC after operating this circuit or use the IC in an environment where the operation of this circuit is assumed.

TSD on temperature [°C] (typ.)	Hysteresis temperature [°C] (typ.)
170	20

(8) Ground Wiring Pattern

When using both small signal and large current GND patterns, it is recommended to isolate the two ground patterns, placing a single ground point at the application's reference point so that the pattern wiring resistance and voltage variations caused by large currents do not cause variations in the small signal ground voltage. Be careful not to change the GND wiring pattern of any external components, either.

### Notes

- No technical content pages of this document may be reproduced in any form or transmitted by any means without prior permission of ROHM CO.,LTD.
- The contents described herein are subject to change without notice. The specifications for the product described in this document are for reference only. Upon actual use, therefore, please request that specifications to be separately delivered.
- Application circuit diagrams and circuit constants contained herein are shown as examples of standard use and operation. Please pay careful attention to the peripheral conditions when designing circuits and deciding upon circuit constants in the set.
- Any data, including, but not limited to application circuit diagrams information, described herein are intended only as illustrations of such devices and not as the specifications for such devices. ROHM CO.,LTD. disclaims any warranty that any use of such devices shall be free from infringement of any third party's intellectual property rights or other proprietary rights, and further, assumes no liability of whatsoever nature in the event of any such infringement, or arising from or connected with or related to the use of such devices.
- Upon the sale of any such devices, other than for buyer's right to use such devices itself, resell or otherwise dispose of the same, no express or implied right or license to practice or commercially exploit any intellectual property rights or other proprietary rights owned or controlled by
- ROHM CO., LTD. is granted to any such buyer.
- Products listed in this document are no antiradiation design.

The products listed in this document are designed to be used with ordinary electronic equipment or devices (such as audio visual equipment, office-automation equipment, communications devices, electrical appliances and electronic toys).

Should you intend to use these products with equipment or devices which require an extremely high level of reliability and the malfunction of which would directly endanger human life (such as medical instruments, transportation equipment, aerospace machinery, nuclear-reactor controllers, fuel controllers and other safety devices), please be sure to consult with our sales representative in advance.

#### About Export Control Order in Japan

Products described herein are the objects of controlled goods in Annex 1 (Item 16) of Export Trade Control Order in Japan.

In case of export from Japan, please confirm if it applies to "objective" criteria or an "informed" (by MITI clause) on the basis of "catch all controls for Non-Proliferation of Weapons of Mass Destruction.

Thank you for your accessing to ROHM product informations.  
More detail product informations and catalogs are available,  
please contact your nearest sales office.

Please contact our sales offices for details ;

U.S.A / San Diego	TEL : +1(858)625-3630	FAX : +1(858)625-3670
Atlanta	TEL : +1(770)754-5972	FAX : +1(770)754-0691
Dallas	TEL : +1(972)312-8818	FAX : +1(972)312-0330
Germany / Dusseldorf	TEL : +49(2154)9210	FAX : +49(2154)921400
United Kingdom / London	TEL : +44(1)908-282-666	FAX : +44(1)908-282-528
France / Paris	TEL : +33(0)1 56 97 30 60	FAX : +33(0) 1 56 97 30 80
China / Hong Kong	TEL : +852(2)740-6262	FAX : +852(2)375-8971
Shanghai	TEL : +86(21)6279-2727	FAX : +86(21)6247-2066
Dilian	TEL : +86(411)8230-8549	FAX : +86(411)8230-8537
Beijing	TEL : +86(10)8525-2483	FAX : +86(10)8525-2489
Taiwan / Taipei	TEL : +866(2)2500-6956	FAX : +866(2)2503-2869
Korea / Seoul	TEL : +82(2)8182-700	FAX : +82(2)8182-715
Singapore	TEL : +65-6332-2322	FAX : +65-6332-5662
Malaysia / Kuala Lumpur	TEL : +60(3)7958-8355	FAX : +60(3)7958-8377
Philippines / Manila	TEL : +63(2)807-6872	FAX : +63(2)809-1422
Thailand / Bangkok	TEL : +66(2)254-4890	FAX : +66(2)256-6334

Japan /  
(Internal Sales)

Tokyo	2-1-1, Yaesu, Chuo-ku, Tokyo 104-0082	TEL : +81(3)5203-0321	FAX : +81(3)5203-0300
Yokohama	2-4-8, Shin Yokohama, Kohoku-ku, Yokohama, Kanagawa 222-8575	TEL : +81(45)476-2131	FAX : +81(45)476-2128
Nagoya	Dainagayo Building 9F 3-28-12, Meieki, Nakamura-ku, Nagoya, Aichi 450-0002	TEL : +81(52)581-8521	FAX : +81(52)561-2173
Kyoto	579-32 Higashi Shiokouji-cho, Karasuma Nishi-iru, Shiokoujidori, Shimogyo-ku, Kyoto 600-8216	TEL : +81(75)311-2121	FAX : +81(75)314-6559

(Contact address for overseas customers in Japan)

Yokohama	TEL : +81(45)476-9270	FAX : +81(045)476-9271
----------	-----------------------	------------------------