

2SD1991A

Silicon NPN epitaxial planer type

For general amplification
Complementary to 2SB1320A

Features

- High forward current transfer ratio h_{FE} .
- Low collector to emitter saturation voltage $V_{CE(sat)}$.
- Allowing supply with the radial taping.

Absolute Maximum Ratings (Ta=25°C)

Parameter	Symbol	Ratings	Unit
Collector to base voltage	V_{CBO}	60	V
Collector to emitter voltage	V_{CEO}	50	V
Emitter to base voltage	V_{EBO}	7	V
Peak collector current	I_{CP}	200	mA
Collector current	I_C	100	mA
Collector power dissipation	P_C	400	mW
Junction temperature	T_j	150	°C
Storage temperature	T_{stg}	-55 ~ +150	°C

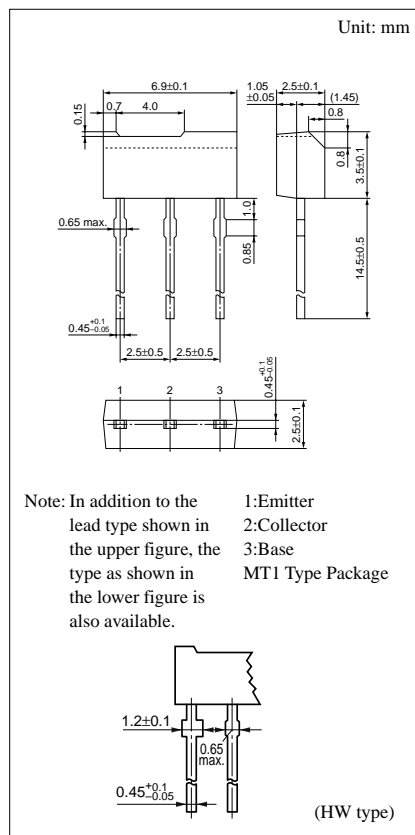

Electrical Characteristics (Ta=25°C)

Parameter	Symbol	Conditions	min	typ	max	Unit
Collector cutoff current	I_{CBO}	$V_{CB} = 20V, I_E = 0$			1	μA
	I_{CEO}	$V_{CE} = 20V, I_B = 0$			1	μA
Collector to base voltage	V_{CBO}	$I_C = 10\mu A, I_E = 0$	60			V
Collector to emitter voltage	V_{CEO}	$I_C = 2mA, I_B = 0$	50			V
Emitter to base voltage	V_{EBO}	$I_E = 10\mu A, I_C = 0$	7			V
Forward current transfer ratio	h_{FE1}^*	$V_{CE} = 10V, I_C = 2mA$	160		460	
	h_{FE2}	$V_{CE} = 2V, I_C = 100mA$	90			
Collector to emitter saturation voltage	$V_{CE(sat)}$	$I_C = 100mA, I_B = 10mA$		0.1	0.3	V
Transition frequency	f_T	$V_{CB} = 10V, I_E = -2mA, f = 200MHz$		150		MHz
Collector output capacitance	C_{ob}	$V_{CB} = 10V, I_E = 0, f = 1MHz$		3.5		pF

* h_{FE1} Rank classification

Rank	Q	R	S
h_{FE1}	160 ~ 260	210 ~ 340	290 ~ 460

$P_C - T_a$

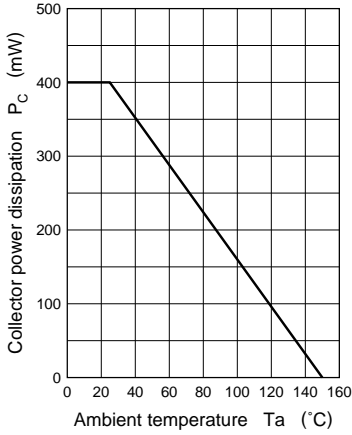

$I_C - V_{CE}$

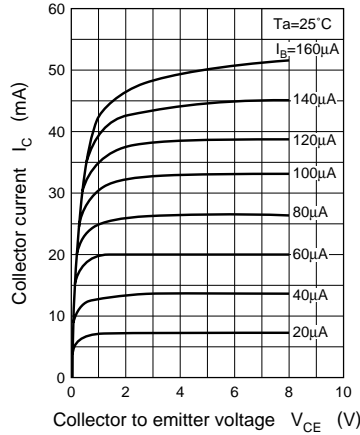

$I_B - V_{BE}$

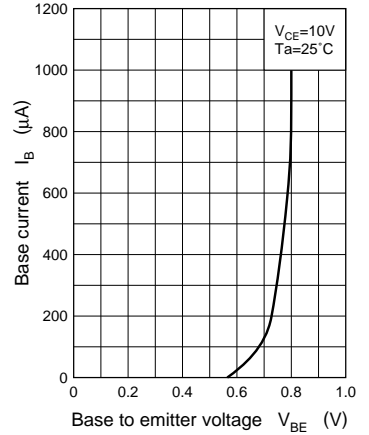

$I_C - V_{BE}$

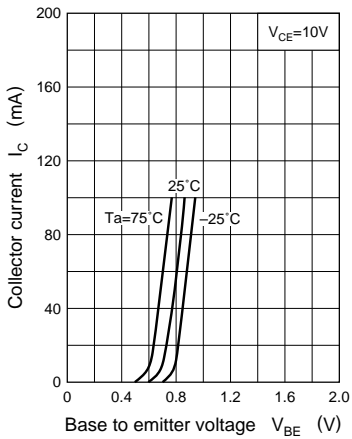

$I_C - I_B$

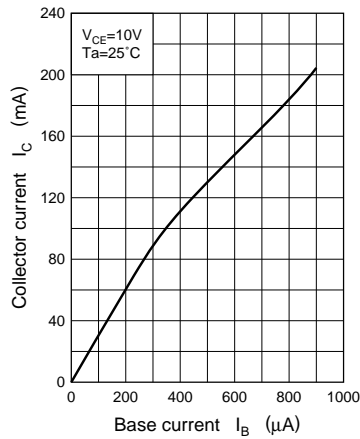

$V_{CE(sat)} - I_C$

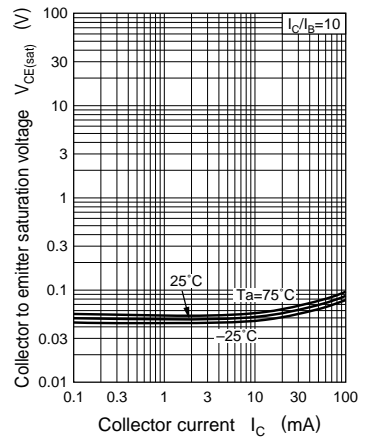

$h_{FE} - I_C$

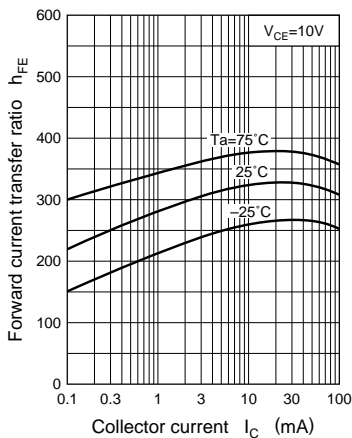

$h_{FE} - I_C$

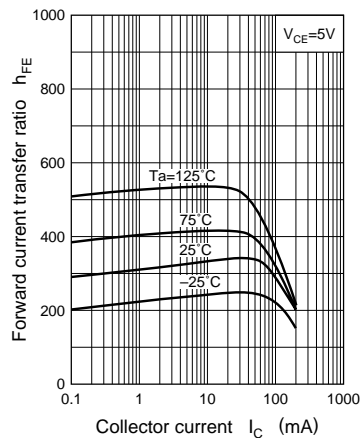

$f_T - I_E$

