

isc Silicon NPN Power Transistor

2SD1266

DESCRIPTION

- Low Collector Saturation Voltage  
:  $V_{CE(sat)} = 1.2V(\text{Max}) @ I_C = 3A$
- Collector-Emitter Breakdown Voltage-  
:  $V_{(BR)CEO} = 60V(\text{Min})$
- Good Linearity of  $h_{FE}$
- Complement to Type 2SB941

APPLICATIONS

- Designed for power amplification.

ABSOLUTE MAXIMUM RATINGS( $T_a=25^\circ\text{C}$ )

SYMBOL	PARAMETER	VALUE	UNIT
$V_{CBO}$	Collector-Base Voltage	60	V
$V_{CEO}$	Collector-Emitter Voltage	60	V
$V_{EBO}$	Emitter-Base Voltage	6	V
$I_C$	Collector Current-Continuous	3	A
$I_{CM}$	Collector Current-Peak	5	A
$P_C$	Collector Power Dissipation @ $T_c=25^\circ\text{C}$	35	W
	Collector Power Dissipation @ $T_a=25^\circ\text{C}$	2	
$T_J$	Junction Temperature	150	$^\circ\text{C}$
$T_{stg}$	Storage Temperature Range	-55~150	$^\circ\text{C}$

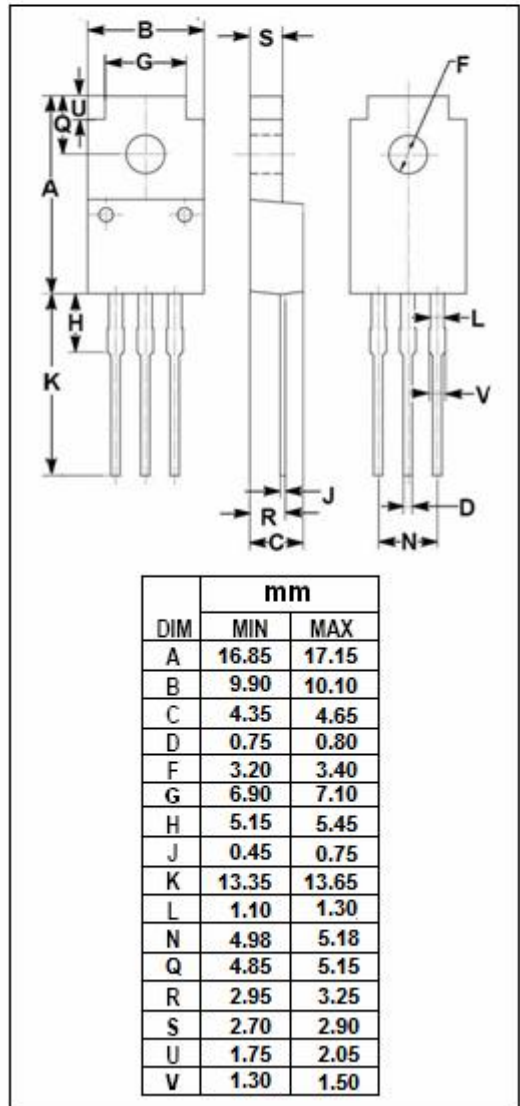
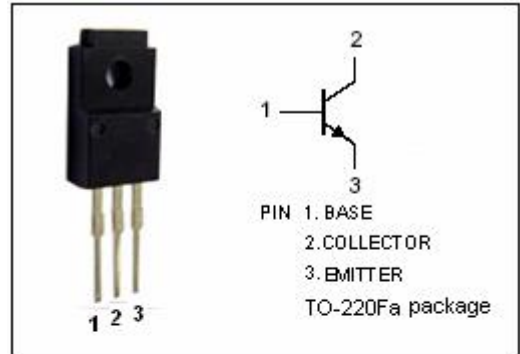

**isc Silicon NPN Power Transistor****2SD1266****ELECTRICAL CHARACTERISTICS** $T_C=25^{\circ}\text{C}$  unless otherwise specified

SYMBOL	PARAMETER	CONDITIONS	MIN	TYP.	MAX	UNIT
$V_{(BR)CEO}$	Collector-Emitter Breakdown Voltage	$I_C=30\text{mA}; I_B=0$	60			V
$V_{CE(sat)}$	Collector-Emitter Saturation Voltage	$I_C=3\text{A}; I_B=0.375\text{A}$			1.2	V
$V_{BE(on)}$	Base-Emitter On Voltage	$I_C=3\text{A}; V_{CE}=4\text{V}$			1.8	V
$I_{CES}$	Collector Cutoff Current	$V_{CE}=60\text{V}; V_{BE}=0$			0.2	mA
$I_{CEO}$	Collector Cutoff Current	$V_{CE}=30\text{V}; I_B=0$			0.3	mA
$I_{EBO}$	Emitter Cutoff Current	$V_{EB}=6\text{V}; I_C=0$			1.0	mA
$h_{FE-1}$	DC Current Gain	$I_C=1\text{A}; V_{CE}=4\text{V}$	70		250	
$h_{FE-2}$	DC Current Gain	$I_C=3\text{A}; V_{CE}=4\text{V}$	10			
$f_T$	Current-Gain—Bandwidth Product	$I_C=0.5\text{A}; V_{CE}=10\text{V}; f=10\text{MHz}$		30		MHz

## Switching times

$t_{on}$	Turn-on Time	$I_C=1\text{A}; I_{B1}=-I_{B2}=0.1\text{A}; V_{CC}=50\text{V}$		0.5		$\mu\text{s}$
$t_{stg}$	Storage Time			2.5		$\mu\text{s}$
$t_f$	Fall Time			0.4		$\mu\text{s}$

**U  $h_{FE-1}$  classifications**

Q	P
70-150	120-250