

**DESCRIPTIONS**

The IP4001 is a monolithic integrated circuit, and suitable for 5-ch motor driver which drives focus actuator, tracking actuator, sled motor, spindle motor and Tray motor of CDP & V-CD system.

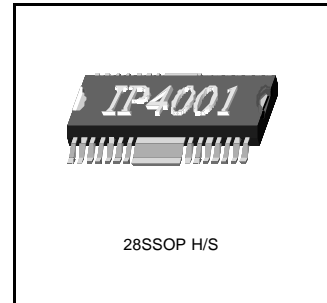

**FEATURES**

- 1ch(forward-reverse) control DC motor driver
- 4ch BTL(Balanced Transformerless) driver
- Built-in TSD (Thermal shutdown) circuit
- Built-in 5V regulator with an internal NPN TR
- Built-in mute circuit
- Built-in Tray motor speed control circuit
- Wide operating supply voltage range: 6.5V~13.2V

**ORDER INFORMATION**

Device	Package	Operating Temp
IP4001	28SSOPH-375	-35°C ~ +85°C
IP4001TF	28SSOPH-375	-35°C ~ +85°C

**BLOCK DIAGRAM**

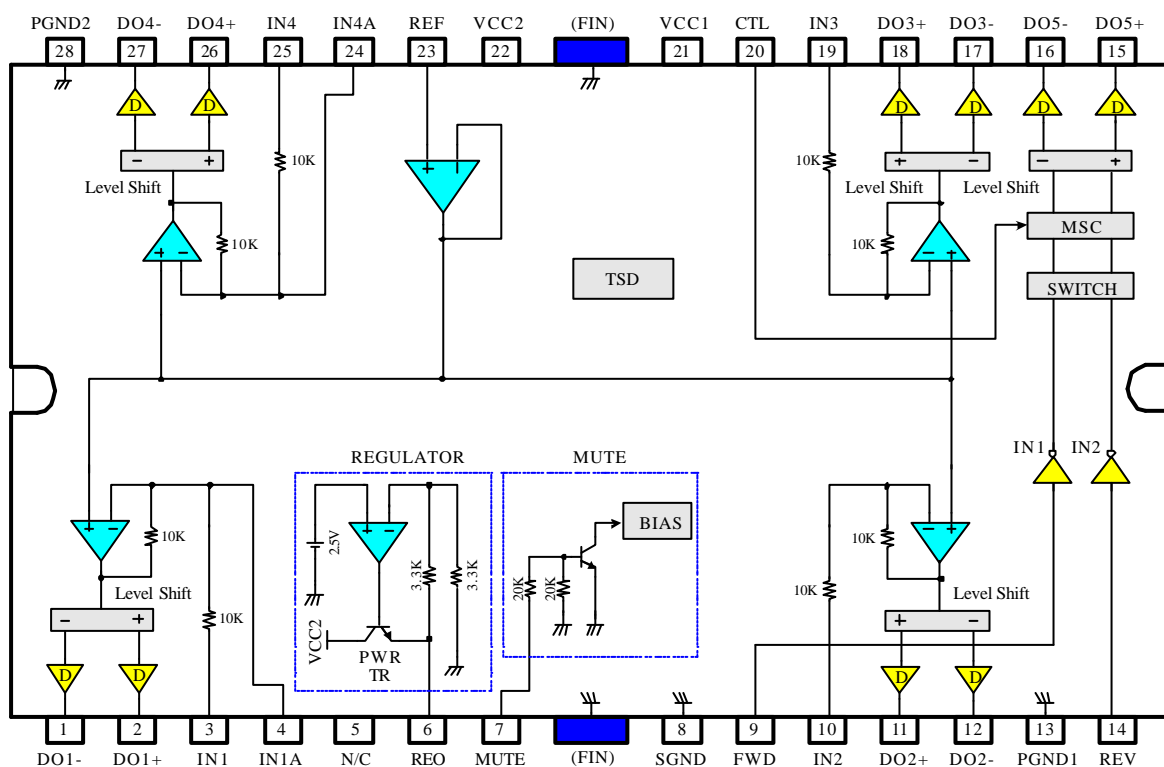

**PIN CONNECTIONS**

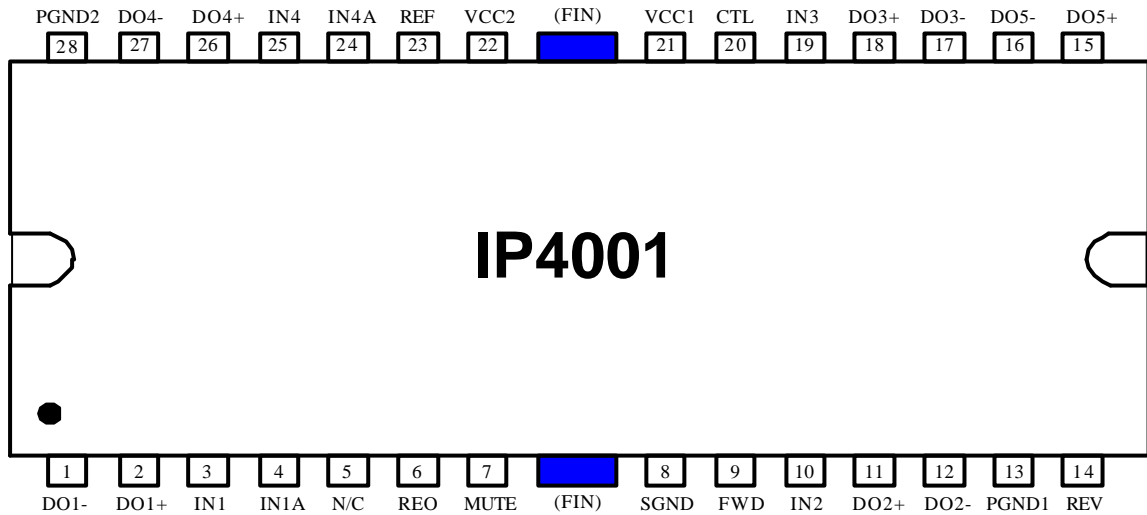

**PIN DESCRIPTIONS**

NO	SYMBOL	I/O	DESCRIPTION	NO	SYMBOL	I/O	DESCRIPTION
1	DO1-	O	CH1 OUTPUT (-)	15	DO5+	O	CH5 OUTPUT (+)
2	DO1+	O	CH1 OUTPUT (+)	16	DO5-	O	CH5 OUTPUT (-)
3	IN1	I	CH1 INPUT 1	17	DO3-	O	CH3 OUTPUT (-)
4	IN1A	I	CH1 INPUT 2	18	DO3+	O	CH3 OUTPUT (+)
5	N / C	-	NO-CONNECTION	19	IN3	I	CH3 INPUT
6	REO	O	REGULATOR OUTPUT	20	CTL	I	CH5 MOTOR SPEED CONTROL
7	MUTE	I	MUTE INPUT	21	VCC1	I	SUPPLY VOLTAGE 1 (CH2,CH3,CH5)
8	SGND	-	SIGNAL GROUND	22	VCC2	I	SUPPLY VOLTAGE 2 (CH1,CH4,SIGNAL,REG)
9	FWD	I	CH5 INPUT 1	23	REF	I	CH BIAS INPUT
10	IN2	I	CH2 INPUT	24	IN4A	I	CH4 INPUT 1
11	DO2+	O	CH2 OUTPUT (+)	25	IN4	I	CH4 INPUT 2
12	DO2-	O	CH2 OUTPUT (-)	26	DO4+	O	CH4 OUTPUT (+)
13	PGND1	-	POWER GROUND 1	27	DO4-	O	CH4 OUTPUT (-)
14	REV	I	CH5 INPUT 2	28	PGND2	-	POWER GROUND 2

**ABSOLUTE MAXIMUM RATINGS**

CHARACTERISTICS	SYMBOL	VALUE	UNIT
Maximum supply voltage	Vccmax	15	V
Power dissipation	Pd	2.3 *	W
Operating temperature	Topr	-35 ~ +85	°C
Storage temperature	Tstg	-55 ~ 150	°C
Maximum output current	Iomax	1	A

Note>

1. When mounted on 50mm X 50mm X 1mm PCB (Phenolic resin material).
2. Power dissipation reduces 18.4 mW/°C for using above Ta=25°C
3. Do not exceed Pd and SOA.

**POWER DISSIPATION CURVE**

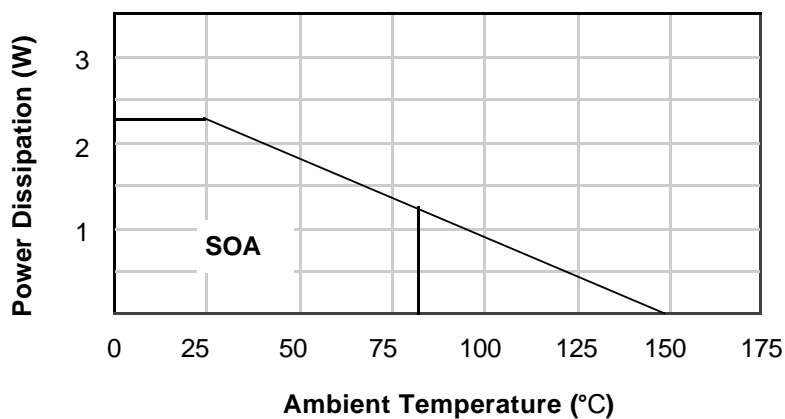

**RECOMMENDED OPERATING CONDITIONS**

CHARACTERISTICS	SYMBOL	VALUE	UNIT
Supply voltage 1	Vcc1	6.5 ~ 13.2	V
Supply voltage 2	Vcc2	6.5 ~ 13.2	V

**ELECTRICAL CHARACTERISTICS**

(Ta = 25°C, VCC1=VCC2=8V, RL=8ohm, unless otherwise specified.)

CHARACTERISTICS	SYMBOL	CONDITIONS	MIN	TYP	MAX	UNIT
Quiescent circuit current	Icc	-	-	10	-	mA
Mute on current	Imute	Pin7=GND	-	2.5	5	mA
Mute on voltage	Vmon	-	-	-	0.5	V
Mute off voltage	Vmoff	-	2	-	-	V
<b>[ BTL DRIVE PART ]</b>						
Output offset voltage	Voo	Vin=2.5V	-40	-	+40	mV
Maximum output voltage	Vom	Vcc1=Vcc2=8V, 8ohm	4	5	-	V
Closed-loop voltage gain	Avf	Vin=0.1Vrms, f=1Khz	5	6.5	8	dB
Ripple rejection ratio	RR	Vin=0.1Vrms, f=120Hz	50	60	-	dB
Slew rate	SR	Vout=4Vp-p, square	-	1.5	-	V/us
<b>[ REGULATOR PART ]</b>						
Output voltage	Vreg	IL=100mA	4.7	5	5.3	V
Load regulation 1	$\Delta$ Vrl 1	IL=0~100mA	-40	-	10	mV
Load regulation 2	$\Delta$ Vrl 2	IL=0~200mA	-70	-	10	mV
Line regulation	Vcc	Vcc=6.5V~12.5V, IL=100mA	-20	-	+60	mV
<b>[ TRAY DRIVE PART ]</b>						
Input high level voltage	Vih	-	2	-	-	V
Input high level voltage	Vil	-	-	-	0.5	V
Output voltage	$\Delta$ Vo	Vcc=8V, RL=45ohm, Pin20=open	2.5	3.1	3.8	V
Output voltage regulation	Vo	Vcc=8V, RL=45ohm, Pin20=3.5V ~ 4.5V	0.6	1	1.4	V
Output offset voltage 1	Voo1	Pin9,Pin14=5V	-40	-	+40	mV
Output offset voltage 2	Voo2	Pin9,Pin14=0V	-40	-	+40	mV

**APPLICATION SUMMARY**

**- Reference & all mute**

When you want to control output bias current of the IP4001, use pin #23 as follows

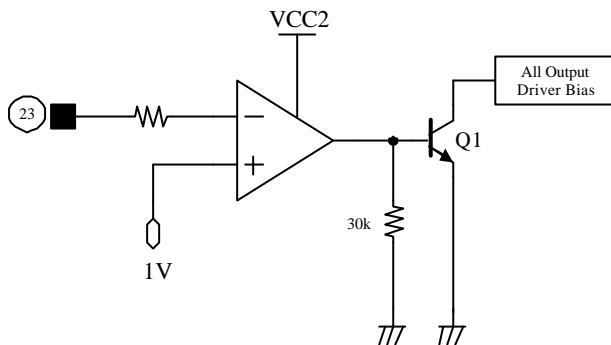

Pin#23	Mute
Above 1.0V	off
Below 1.0V	on

As shown in figure 1, Pin#23 is a negative input of the comparator, and the other Input is the 1.0V reference. If the voltage of the pin#23 falls below 1.0V, TR Q1 will be turned on and the output bias current will be shut down

Fig1. Reference & all mute function

**- Mute**

When you want to control output bias current of the IP4001, you can also use pin#7 as follows

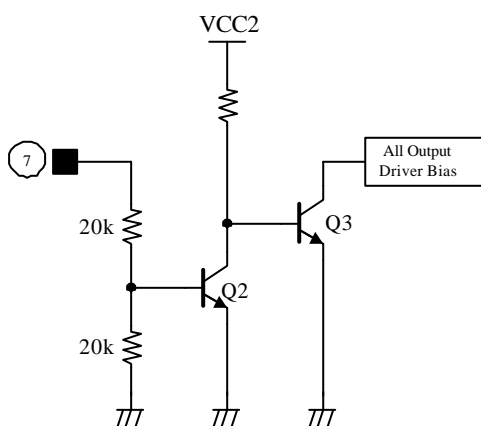

Pin#7	Mute
High	off
Low	on

As shown in figure 2, Pin#7 is a base input of the TR Q2. If the voltage of the pin#7 is low or open, TR Q2 will be turned off and TR Q3 will be turned on, so the bias current will be shut down by TR Q3. If the voltage of the pin#7 is high, the bias circuit operates normally.

Fig2. Mute function

**APPLICATION SUMMARY (Continued)**

**- Thermal shutdown**

The IP4001 has a thermal protection against the abnormal operation, and the detailed operation of the TSD circuit is as follows

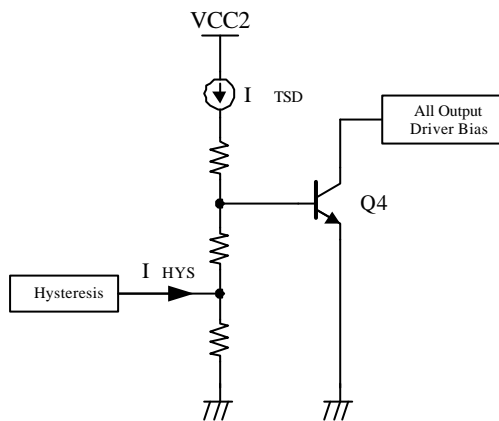

Fig3. Thermal shut down

Temperature	mute
Above 175 °C	on
Falls below 150 °C	off
Hysteresis	25 °C

As shown in figure 3, TSD circuit controls the base of the TR Q4. If the junction temperature rises above 175°C, TR Q4 will be turned on, and the bias current of the output drive circuit will be shut down (because of the negative temperature characteristic of the NPN transistor).

And then temperature falls below 150 °C, TR Q4 will be turned off.

(hysteresis temperature is about to 25 °C)

**- BTL drive part (Focus, Tracking, Spindle, Sled drive part)**

BTL drive part is composed of V-I converter, level shifter and output power amp.

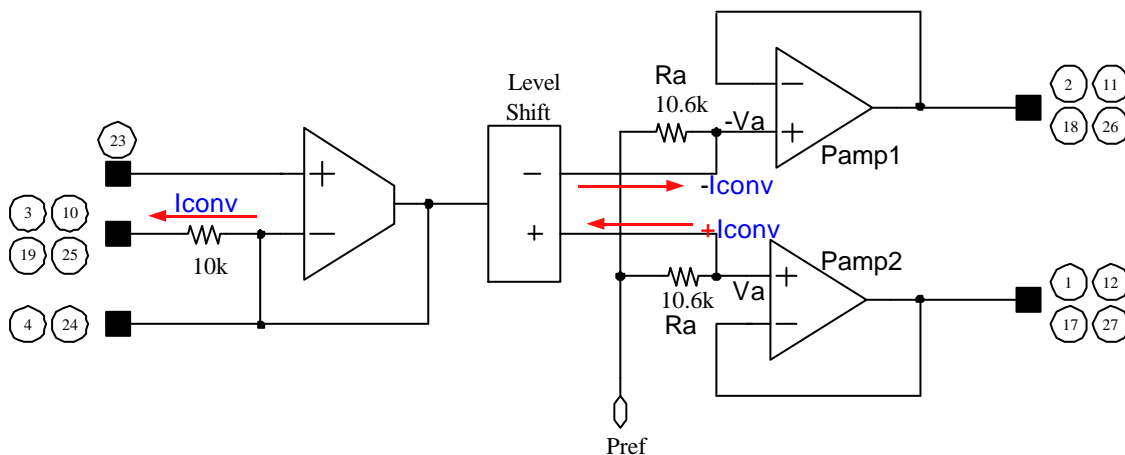

Fig4. BTL drive part

- V-I converter converts voltage of the input pin into current,

$$I_{conv} = \frac{V_{in} - V_{ref}}{10k}$$

\*  $V_{in}$  = input voltage of the input pin (pin3, 10, 19, 25) \*  $V_{ref}$  = reference voltage (pin23)

The level shifter changes the direction of the current( $I_{conv}$ ) as the same amount, and then supply it to the power AMP.

The resistor  $R_a(10.6K)$  converts current into voltage with the DC offset of  $P_{ref}$ .

$$V_a = 10.6K \times \frac{V_{in} - V_{ref}}{10k} + P_{ref}$$

$$-V_a = -10.6K \times \frac{V_{in} - V_{ref}}{10k} + P_{ref} \quad \text{when} \quad P_{ref} = \frac{V_{CC1} - V_{be}}{2}$$

The power amp has unity gain.

So the total differential voltage gain of the IP4001 is as follows,

$$\text{Gain} = 20 \log \frac{\{[10.6k \times \frac{V_{in} - V_{ref}}{10k} + P_{ref}] - [(-)10.6k \times \frac{V_{in} - V_{ref}}{10k} + P_{ref}]\}}{V_{in} - V_{ref}}$$

$$= 20 \log 2 \times \frac{10.6K}{10K}$$

$$= 6.527 \text{dB}$$

If you want to reduce the total gain of the BTL drive part, use additional series resistor into the input pin(pin#3, 10,19,25)

You can also increase or decrease the voltage gain of the CH1, CH4 using adjustable pin (pin#4, pin24) by inserting an external series resistor.

**APPLICATION SUMMARY (Continued)**

**- Tray motor drive part**

CH5 is a forward-reverse control DC motor driver and it is composed of logic control part, level shifter, and output power amp.

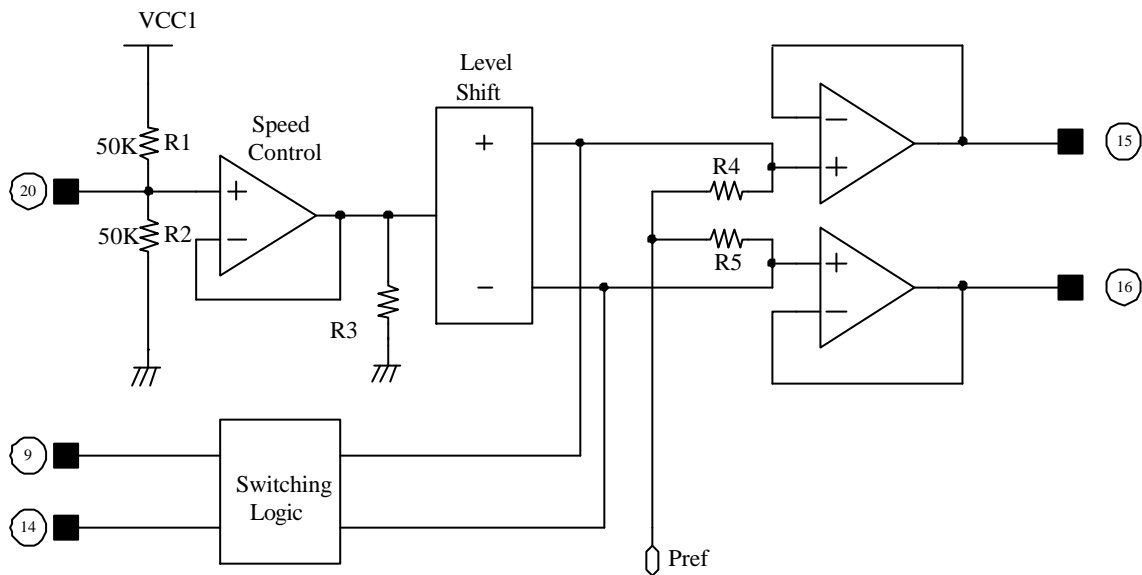

Fig5. Tray drive part

The forward and reverse rotation is controlled by pin9(fwd), pin14(rev) and the amplitude of the output voltage is controlled by pin20(CTL).

The output status due to the input conditions are as follows

INPUT		OUTPUT		
FWD(PIN9)	REV(PIN14)	DO5+(PIN15)	DO5-(PIN16)	STATUS
High	High	Vp	Vp	Brake
High	Low	High	Low	Forward
Low	High	Low	High	Reverse
Low	Low	Vp	Vp	Brake



**APPLICATION SUMMARY (Continued)**

**- Tray motor speed control**

The amplitude of the output voltage is controlled by pin20(CTL).

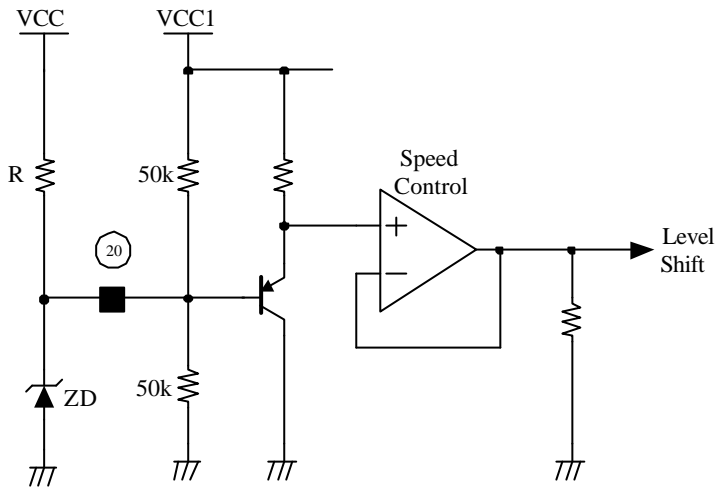

Fig6. Tray motor speed control

Normally, the differential output voltage is 3.1V when the pin20(CTL) is open.

If you want to control differential output voltage of the tray drive part, insert external resistor R and zener diode ZD as shown in figure 6.

Zener diode ZD is only needed when you want to obtain a precision output voltage, In other case you only insert an external resistor R.

**- Regulator part**

IP4001 has a temperature independent voltage source internally.

So in the figure 7, the reference voltage (2.5V) is generated by the internal circuit (bandgab reference).

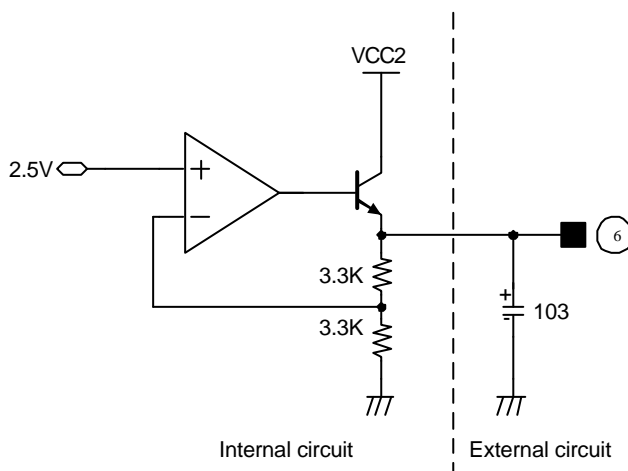

Fig7. Regulator

Because the power NPN TR Q5 is inserted internally, there is no need to attach an external active component.

The output voltage of the regulator is Calculated as follows

$$V_{reg} = \left(1 + \frac{3.3K}{3.3K}\right) \times 2.5 = 5V$$

And the capacitor 1uF is used as a ripple & noise eliminator and should have a good Temperature characteristics.

**TEST CIRCUIT**

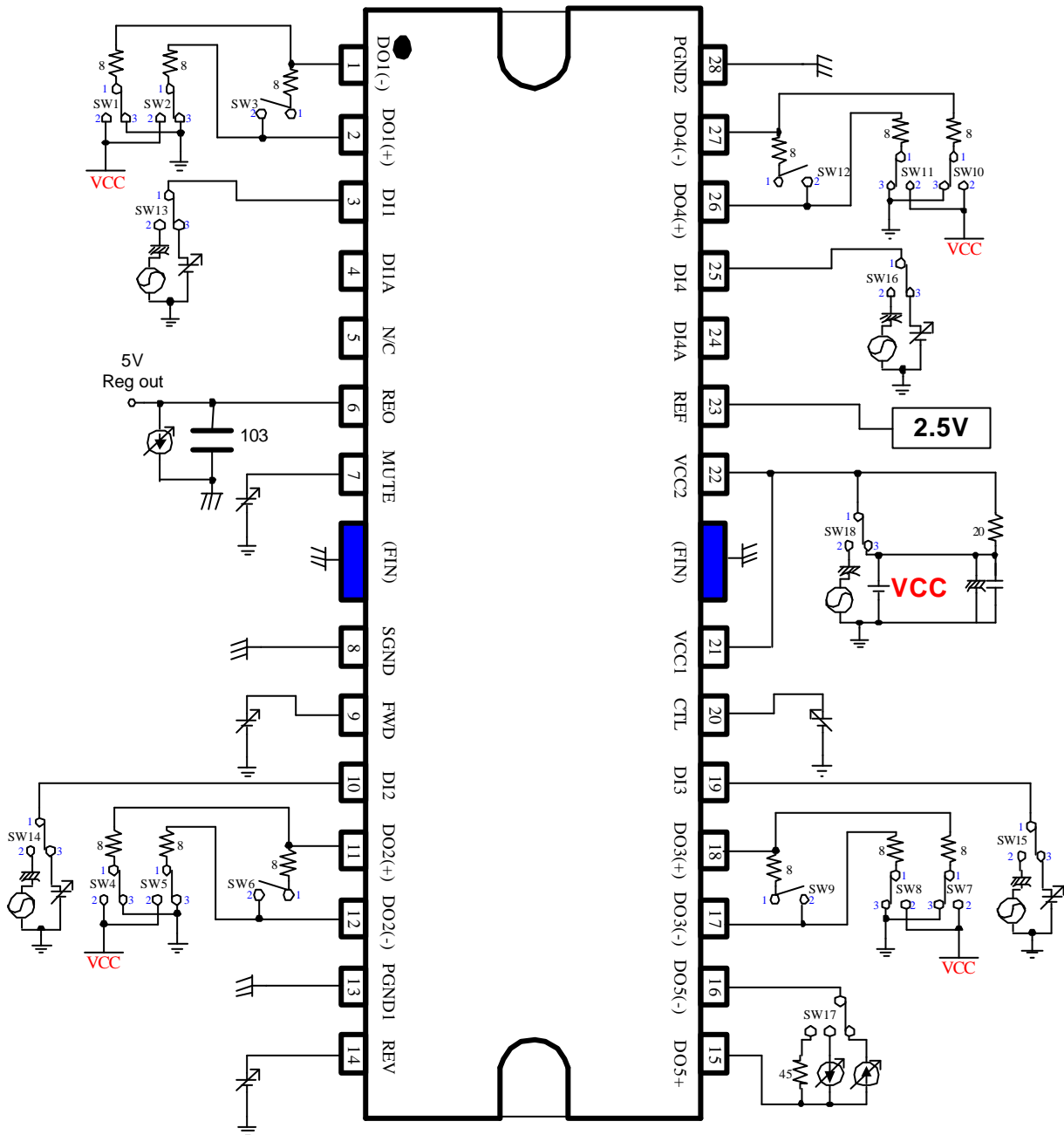

**TYPICAL APPLICATION CIRCUIT**

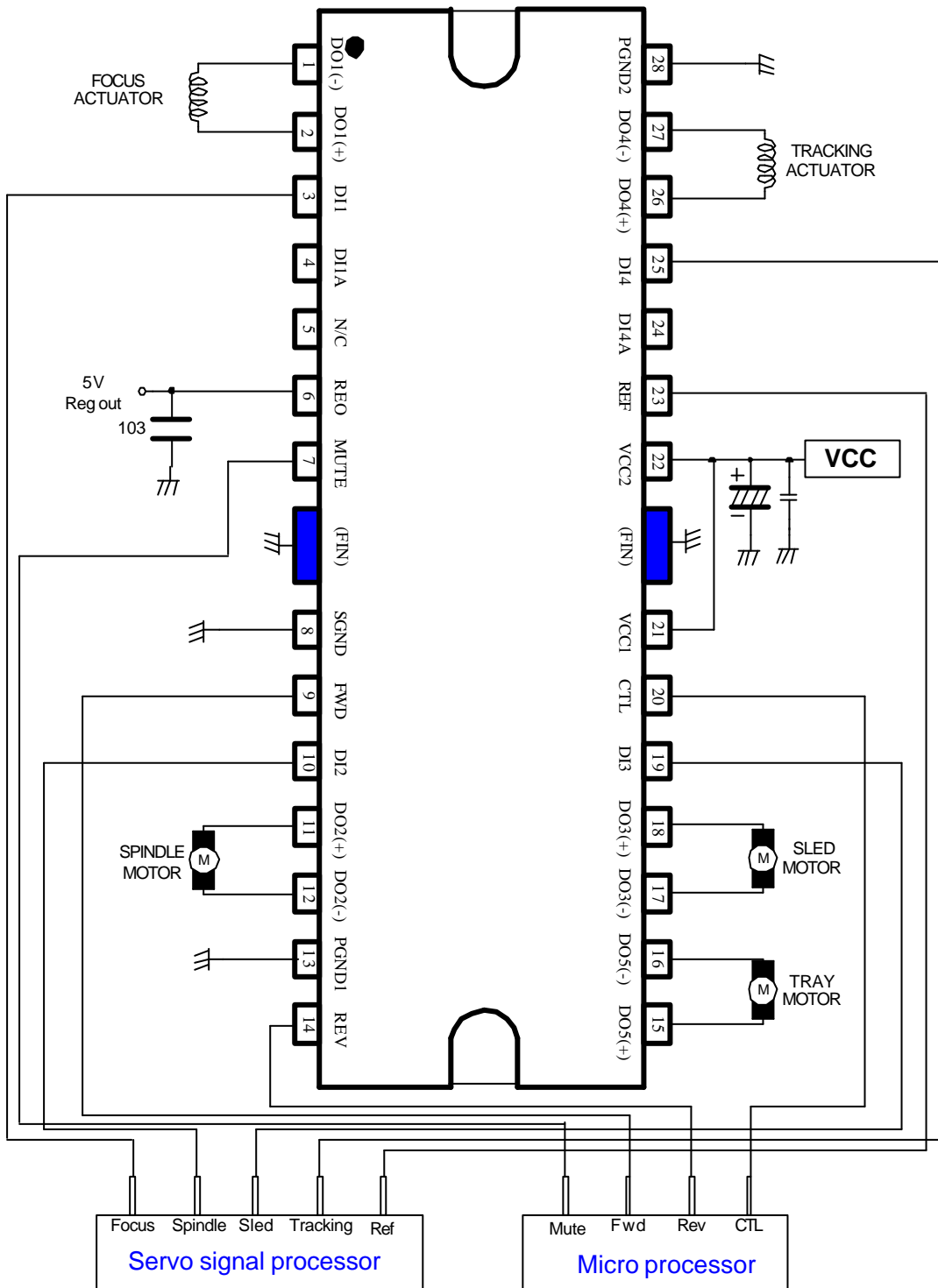

**INTERNAL CIRCUIT**

Pin no	Pin name	Internal circuit
1,2, 11,12, 15,16, 17,18, 26,27	DO1- DO1+ DO2+ DO2- DO5+ DO5- DO3- DO3+ DO5+ DO5-	
3, 4, 10, 19, 23, 24, 25,	IN1 IN1A IN2 IN3 REF IN4A IN4	

**INTERNAL CIRCUIT (Continued)**

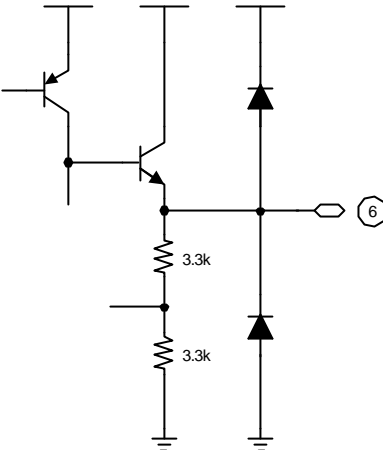
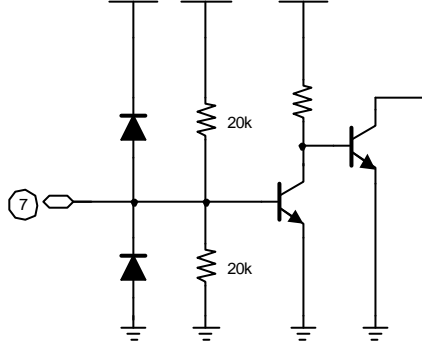
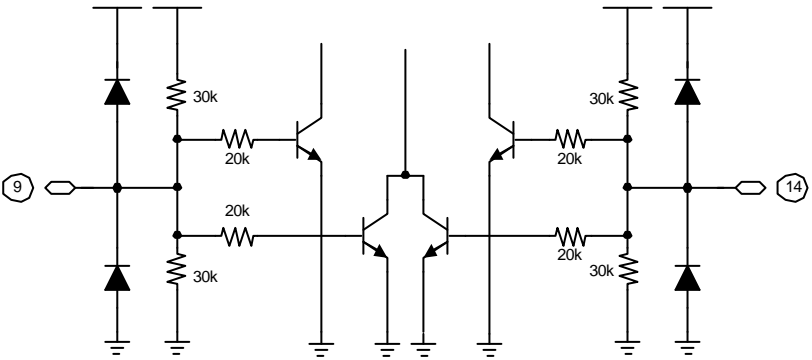
Pin no	Pin name	Internal circuit
6	REO	
7	MUTE	
9,14	FWD REV	

**INTERNAL CIRCUIT (Continued)**

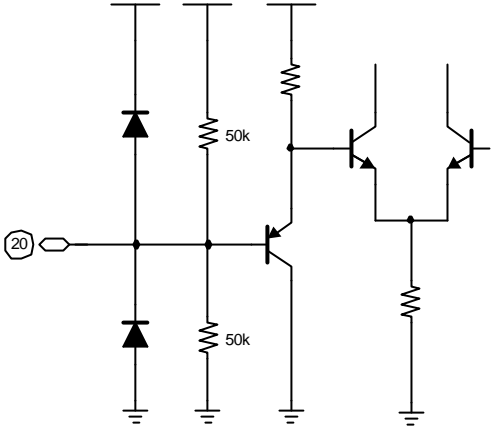
Pin no	Pin name	Internal circuit
20	CTL	

**ELECTRICAL CHARACTERISTICS CURVES**

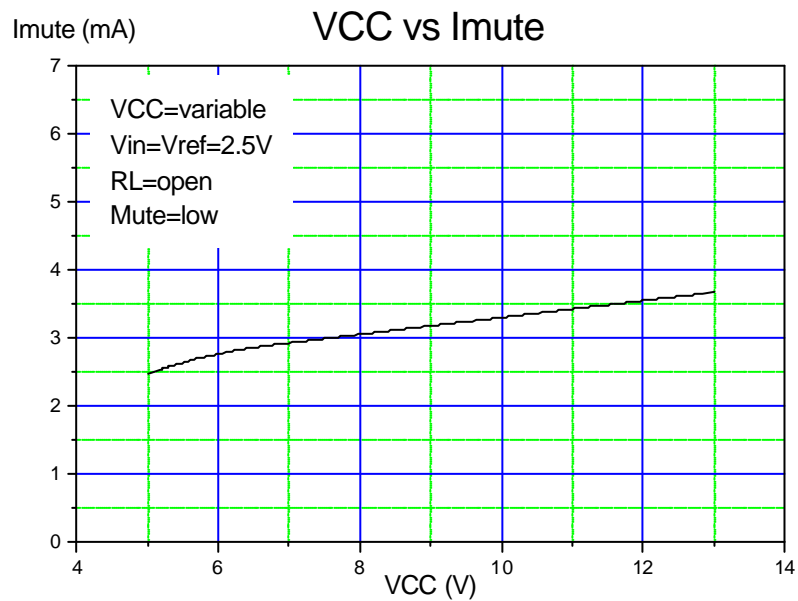
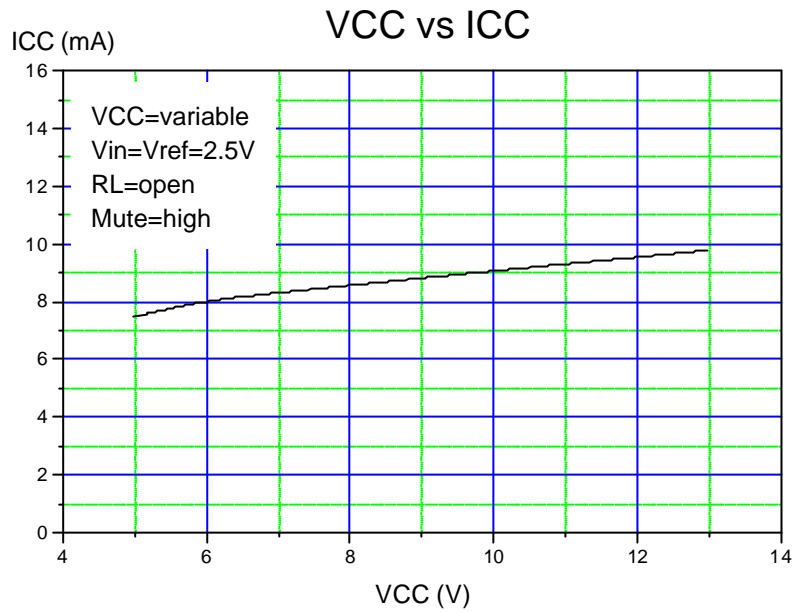

**ELECTRICAL CHARACTERISTICS CURVES (Continued)**

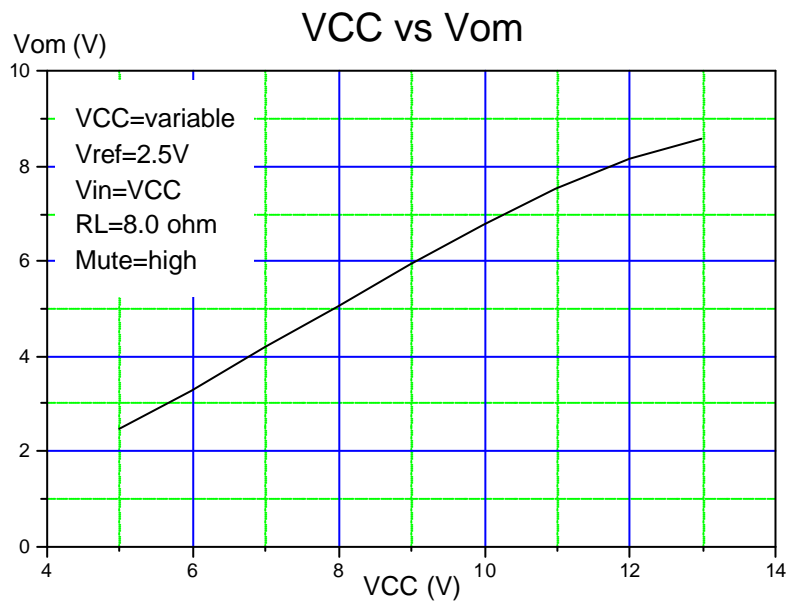
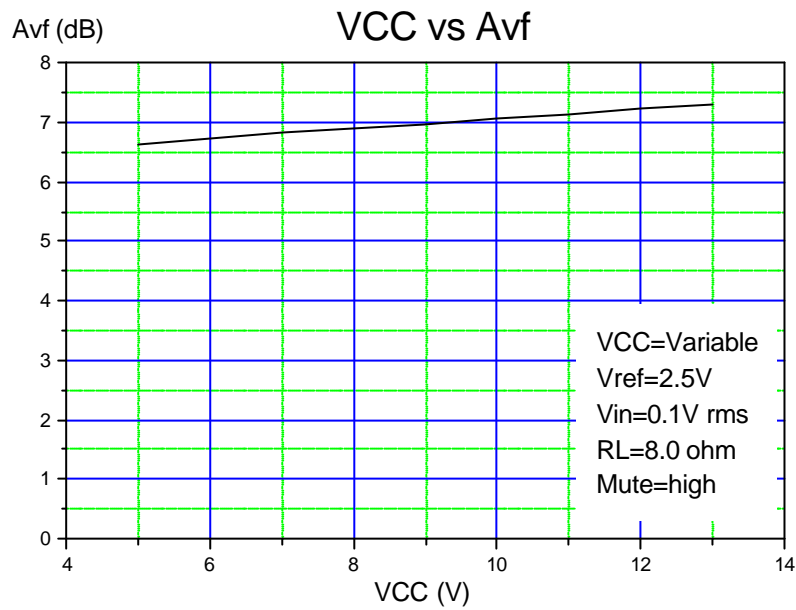



**ELECTRICAL CHARACTERISTICS CURVES (Continued)**

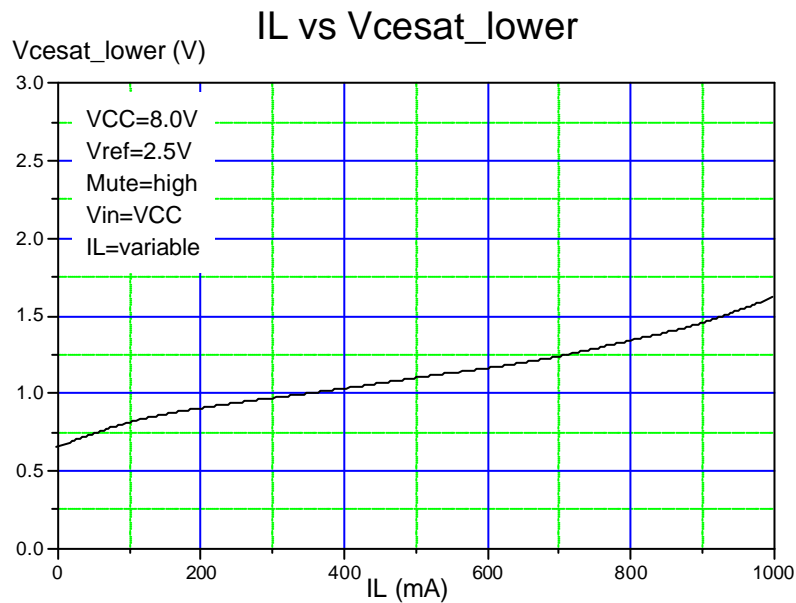
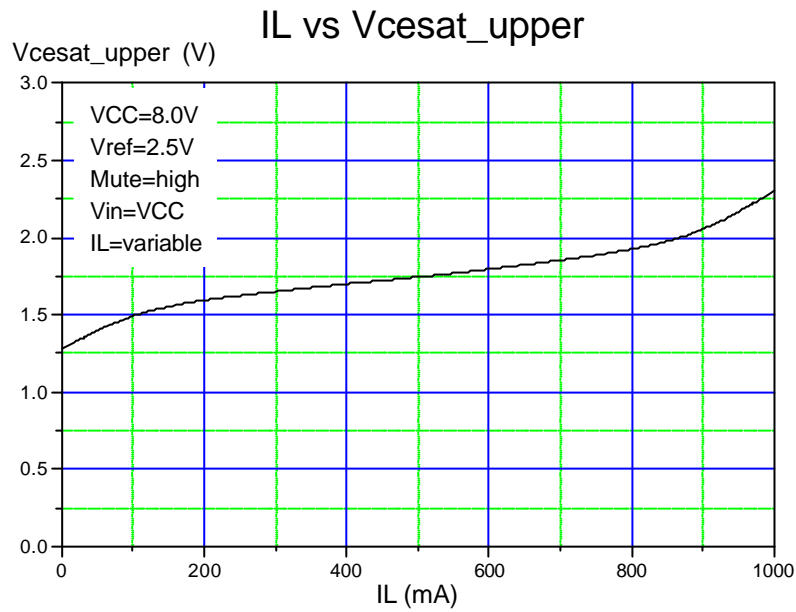

**ELECTRICAL CHARACTERISTICS CURVES (Continued)**

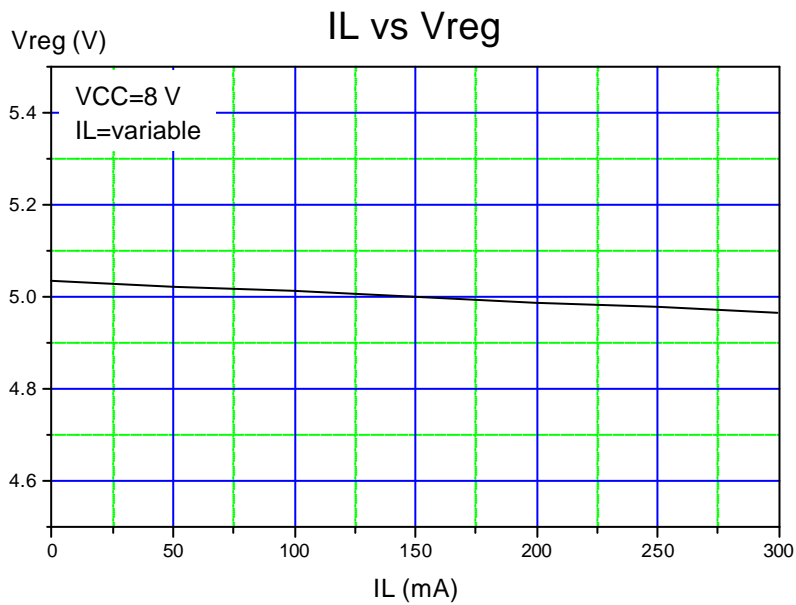
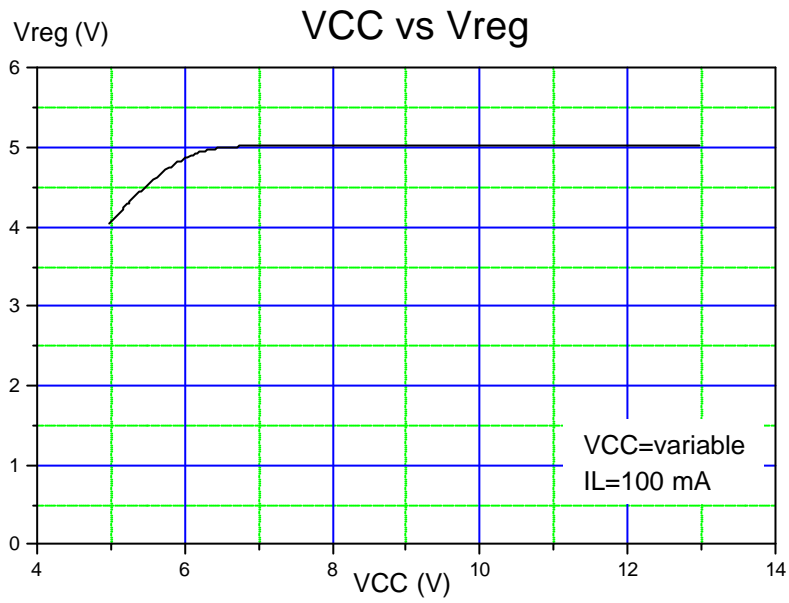

**ELECTRICAL CHARACTERISTICS CURVES (Continued)**

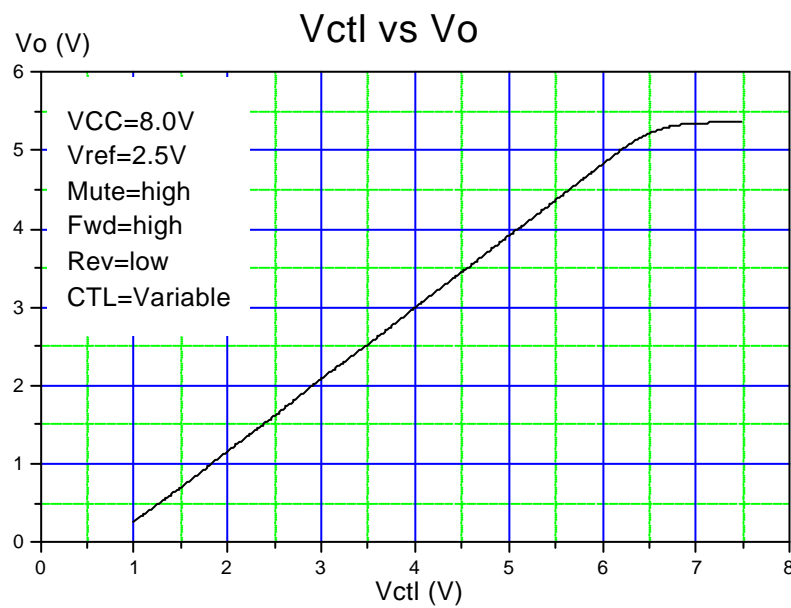
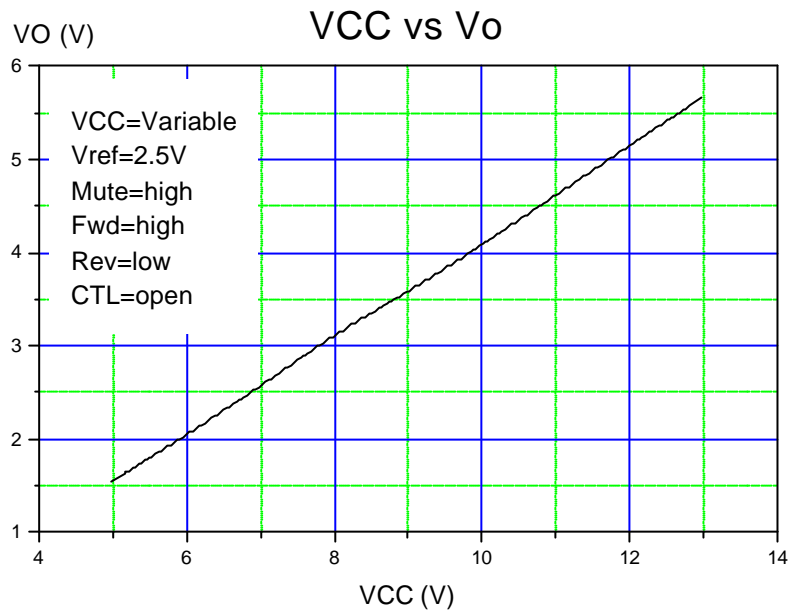

**ELECTRICAL CHARACTERISTICS CURVES (Continued)**

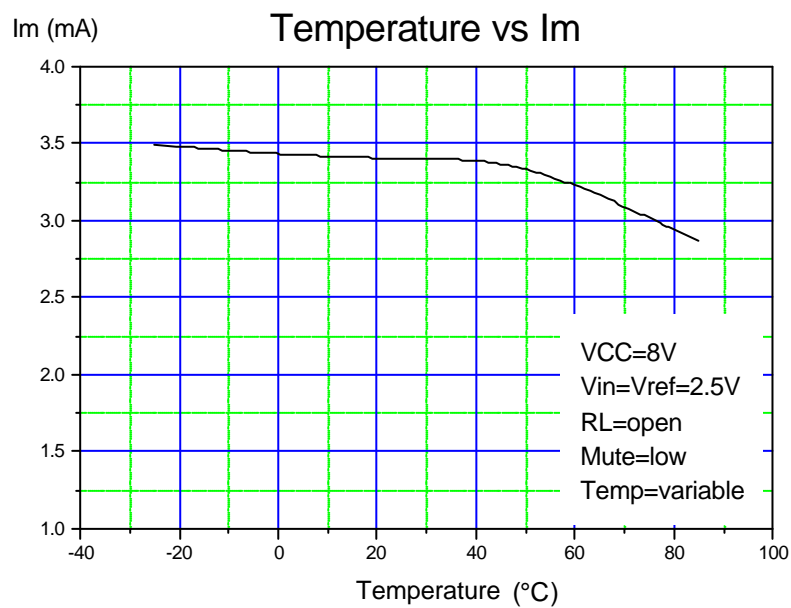
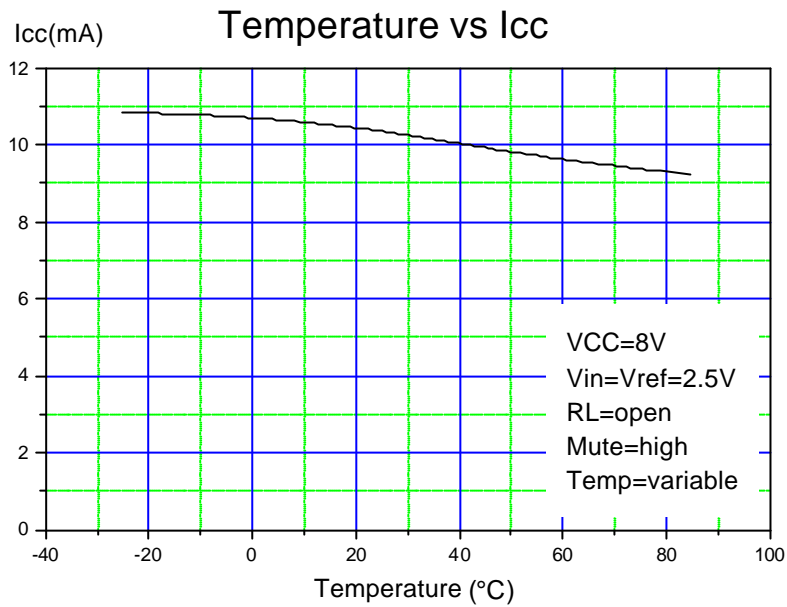

**ELECTRICAL CHARACTERISTICS CURVES (Continued)**

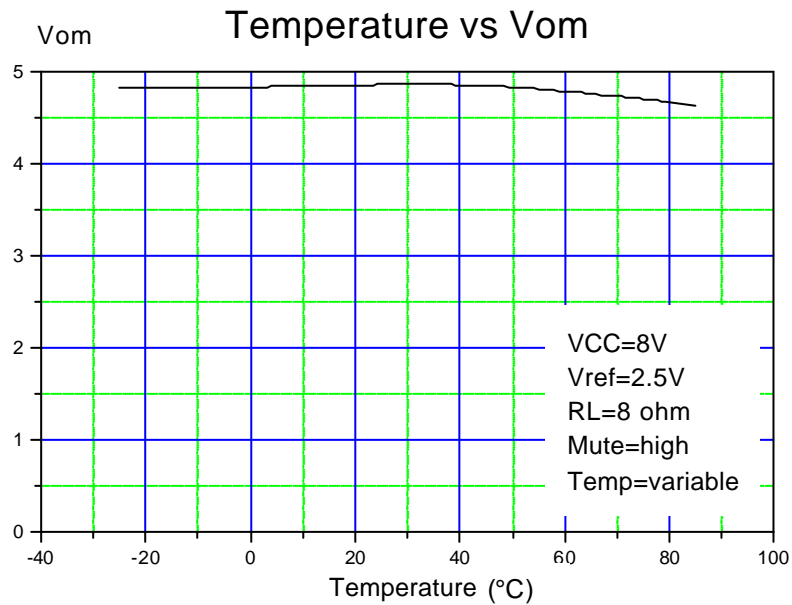
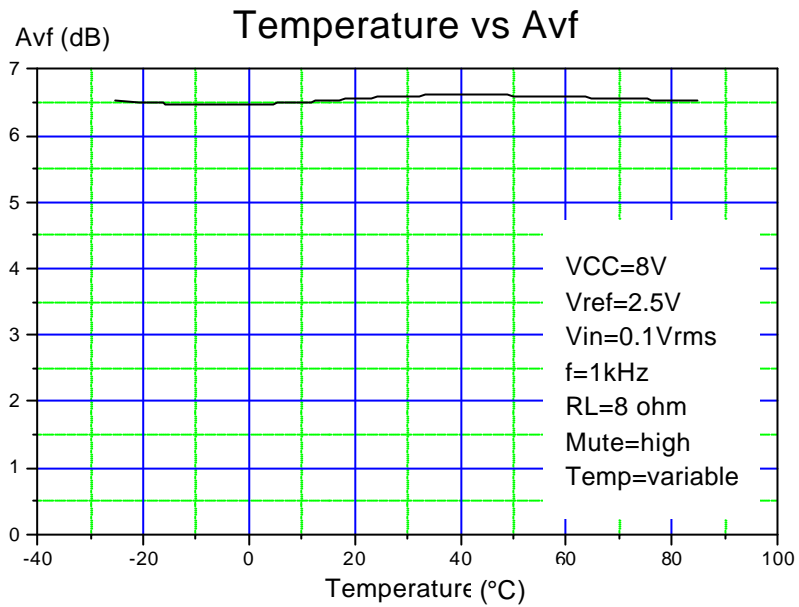

**ELECTRICAL CHARACTERISTICS CURVES (Continued)**

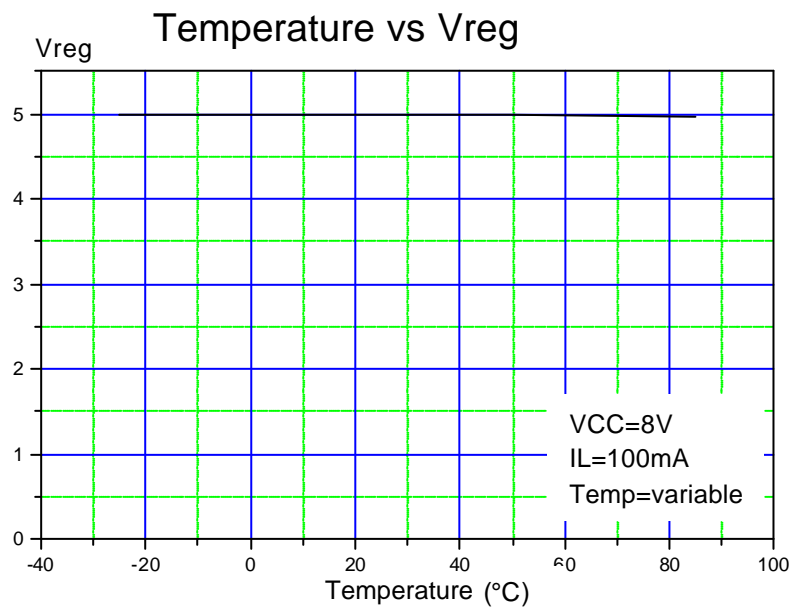
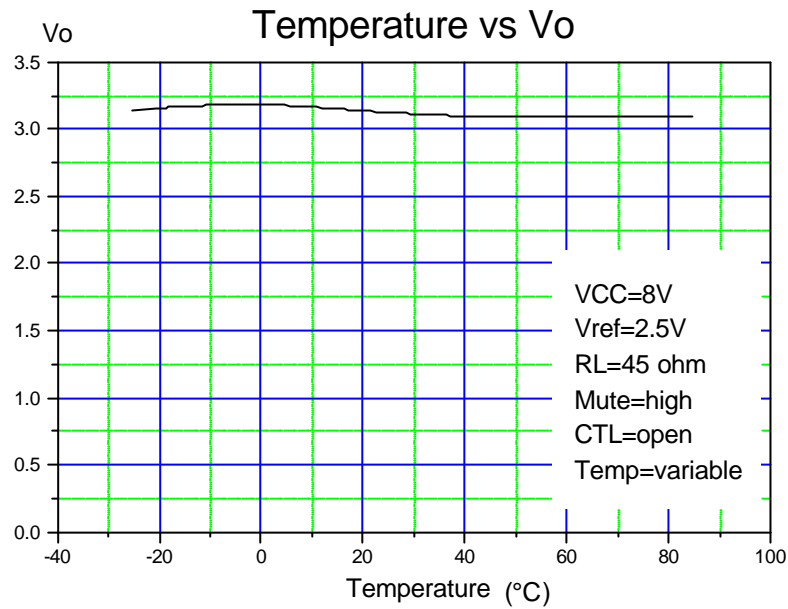

PACKAGE DIMENSION

