

INA 84C640/030

8-BIT MICROCONTROLLERS WITH OCD AND VST

Microcontroller is manufactured in 42-lead plastic DIP-package 2171?.42-A.
Device is functionally identical to the PCA84C640/030 Philips.

BASIC FEATURES.

- Manufactured in 2 μ m silicon gate CMOS process
- TV set switch on/off
- receiving channel subbaund switching
- fine tuning receiving channel
- automatic frequency control
- PAL/SECAM switching
- volume, brightness, contrast control
- Pispay 3On Screen forility
- Operating temperature: -10 - +70⁰C

BASIC ELECTRICAL CHARACTERISTICS

- Power supply voltage, V	4.5.....5.5
- Supply current, mA	16
- Clock frequency, MHz	10
- Output current LOW for P1, DPO,DP1 ports and LOW3 and VOB pins, mA	2.5
- Output current LOW for port P0, mA	7.5
- Output voltage HIGH, V	3.7

BLOCK SCHEME

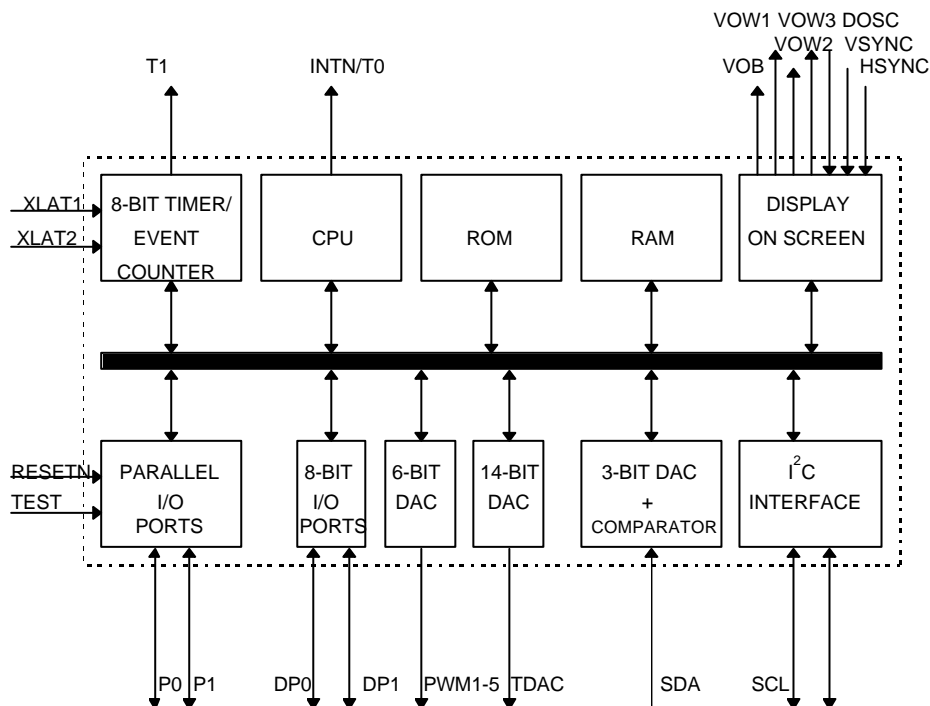

Korzhenevskogo 12, Minsk, 220064, Republic of Belarus
 Fax: +375 (17) 278 28 22,
 Phone: +375 (17) 278 07 11, 277 24 70, 277 24 61,
 277 69 16
 E-mail: belms@belms.belpak.minsk.by
 URL: www.bms.by

BELMICROSYSTEMS

INA 84C640/030

PIN DESCRIPTION

PIN	SYMBOL	DESCRIPTION
1	DP0.0/Tdac	Derivative Port 0: quasi-bidirectional I/O line or 14-bit DAC PWM
2	DP0.1/PWM1	Derivative Port 1: quasi-bidirectional I/O line or 6-bit DAC PWM
3	DP0.2/PWM2	Derivative Port 1: quasi-bidirectional I/O line or 6-bit DAC PWM
4	DP0.3/PWM3	Derivative Port 1: quasi-bidirectional I/O line or 6-bit DAC PWM
5	DP0.4/PWM4	Derivative Port 1: quasi-bidirectional I/O line or 6-bit DAC PWM
6	DP0.5/PWM5	Derivative Port 1: quasi-bidirectional I/O line or 6-bit DAC PWM
7	P1.0/VHF1	Port 1: quasi-bidirectional I/O lines
8	P1.1/VHF3	Port 1: quasi-bidirectional I/O lines
9	P1.7/AFC	Derivative Port 1: quasi-bidirectional I/O line or comparator input with 3-bit DAC
10	P1.2/VHF	Port 1: quasi-bidirectional I/O lines
11	P1.3/VTR	Port 1: quasi-bidirectional I/O lines
12	P1.4/AV	Port 1: quasi-bidirectional I/O lines
13	P0.0	Port 0: quasi-bidirectional I/O port
14	P0.1	Port 0: quasi-bidirectional I/O port
15	P0.2	Port 0: quasi-bidirectional I/O port
16	P0.3	Port 0: quasi-bidirectional I/O port
17	P0.4	Port 0: quasi-bidirectional I/O port
18	P0.5	Port 0: quasi-bidirectional I/O port
19	P0.6	Port 0: quasi-bidirectional I/O port
20	P0.7/Mdstr	Port 0: quasi-bidirectional I/O port
21	V_{ss}	Ground
22	DP1.6/VOW1	Derivative Port 1: quasi-bidirectional I/O lines or character video output
23	DP1.5/VOW2	Derivative Port 1: quasi-bidirectional I/O lines or character video output
24	VOW3	Character video output of OSD
25	Fbl	Blanking output
26	HSYNC	Horizontal synchronous signal input
27	VSYNC	Vertical synchronous signal input
28	DOSC	Connection to RC oscillator of OSD clock
29	IDENT	Direct testable pin and event counter input
30	Test	Control input for testing and emulation mode. Ground for normal operation
31	Xlat 1	Oscillator output or input terminal for system clock
32	Xlat 2	Oscillator output or input terminal for system clock
33	Reset M	Initialise input, active LOW
34	DP1.4/Sudl	Derivative Port 1: quasi-bidirectional I/O lines
35	Int/Rmot	External interrupt or direct testable
36	DP1.3/Sndo	Derivative Port 1: quasi-bidirectional I/O lines
37	DP1.2/Effect	Derivative Port 1: quasi-bidirectional I/O lines
38	DP1.1/P/S	Derivative Port 1: quasi-bidirectional I/O lines
39	DP0.7/SCL	Derivative open drain I/O port or I ² C-bus clock line
40	DP0.6/SDA	Derivative open drain I/O port or I ² C-bus data line
41	DP1.0/Stdby	Derivative Port 1: quasi-bidirectional I/O lines
42	V_{DD}	Power supply

